



U.S. Chemical Safety and  
Hazard Investigation Board

# Fatal Well Blowout at Daniel H. Wendland 1-H Well

Burleson County, Texas | Incident Date: January 29, 2020 | No. 2020-04-I-TX

## Investigation Report

Published: December 2023



### SAFETY ISSUES:

- Well Planning
- Well Control for Completed Wells in Underpressured Reservoirs
- Ignition Source Management
- Federal Regulatory Safety Requirements



## CONTENTS

|  |           |
|--|-----------|
| CONTENTS.....  | 1         |
| ABBREVIATIONS .....                                      | 3         |
| GLOSSARY.....  | 4         |
| EXECUTIVE SUMMARY .....                                  | 8         |
| <b>1 BACKGROUND.....</b>                                 | <b>13</b> |
| 1.1 Companies Involved at the Time of the Incident ..... | 13        |
| 1.1.1 Chesapeake Operating, L.L.C. ....                  | 13        |
| 1.1.2 SDS Petroleum Consultants, L.L.C. ....             | 13        |
| 1.1.3 CC Forbes, LLC.....                                | 13        |
| 1.1.4 Eagle PCO LLC.....                                 | 13        |
| 1.1.5 A&L Hot Oil Service Inc. ....                      | 13        |
| 1.1.6 Workover beginning January 27, 2020.....           | 13        |
| 1.2 Daniel H. Wendland 1-H Well .....                    | 14        |
| 1.3 Oil and Gas Production in the United States .....    | 15        |
| 1.4 Description of Surrounding Area .....                | 16        |
| 1.5 Oil Production Concepts and Terminology.....         | 18        |
| 1.5.1 Petroleum Reservoir Basics.....                    | 18        |
| 1.5.2 Reservoir Pressure and Hydrostatic Pressure .....  | 18        |
| 1.5.3 Well Workovers.....                                | 20        |
| 1.5.4 Well Control .....                                 | 21        |
| <b>2 INCIDENT DESCRIPTION.....</b>                       | <b>23</b> |
| 2.1 Workover Planning.....                               | 23        |
| 2.2 Workover Activities .....                            | 23        |
| 2.3 Well Blowout and Fire.....                           | 28        |
| 2.4 Emergency Response .....                             | 29        |
| 2.5 Incident Consequences .....                          | 31        |
| <b>3 TECHNICAL ANALYSIS.....</b>                         | <b>32</b> |
| 3.1 Wellbore Conditions on the Day of the Incident.....  | 32        |
| <b>4 SAFETY ISSUES .....</b>                             | <b>38</b> |

|          |   |           |
|----------|---|-----------|
| 4.1      | Well Planning.....  | 38        |
| 4.2      | Well Control for Completed Wells in Underpressured Reservoirs ..... | 39        |
| 4.2.1    | <i>Ineffective Hydrostatic Barrier</i> .....                        | 42        |
| 4.2.2    | <i>Ineffective Secondary Barrier</i> .....                          | 42        |
| 4.2.3    | <i>Industry Guidance</i> .....                                      | 46        |
| 4.3      | Ignition Source Management .....                                    | 49        |
| 4.3.1    | <i>Potential Ignition Sources</i> .....                             | 49        |
| 4.3.2    | <i>Insufficient Risk Assessment</i> .....                           | 51        |
| 4.4      | Federal Regulatory Safety Requirements .....                        | 54        |
| 4.4.1    | <i>Control of Hazardous Energy</i> .....                            | 54        |
| 4.4.2    | <i>Process Safety Management</i> .....                              | 56        |
| 4.4.3    | <i>Justification for federal regulation</i> .....                   | 59        |
| <b>5</b> | <b>CONCLUSIONS .....</b>  | <b>64</b> |
| 5.1      | Findings .....  | 64        |
| 5.2      | Cause .....   | 65        |
| <b>6</b> | <b>RECOMMENDATIONS .....</b>  | <b>66</b> |
| 6.1      | Previously Issued Recommendations Superseded in This Report .....   | 66        |
| 6.2      | Recommendations Issued in This Report .....                         | 67        |
| 6.2.1    | <i>Chesapeake Operating, L.L.C.</i> .....                           | 67        |
| 6.2.2    | <i>American Petroleum Institute</i> .....                           | 67        |
| 6.2.3    | <i>Occupational Safety and Health Administration</i> .....          | 67        |
| <b>7</b> | <b>KEY LESSONS FOR THE INDUSTRY .....</b>                           | <b>69</b> |
| <b>8</b> | <b>REFERENCES .....</b>   | <b>70</b> |
|          | APPENDIX A—SIMPLIFIED CAUSAL ANALYSIS (ACCIMAP) .....               | 72        |
|          | APPENDIX B—CALCULATIONS.....  | 73        |
|          | APPENDIX C—WELL WORKOVER HISTORY.....                               | 76        |

## ABBREVIATIONS

|                |  |
|----------------|--|
| <b>API</b>     | American Petroleum Institute   |
| <b>BBL</b>     | barrel   |
| <b>BOP</b>     | blowout preventer  |
| <b>CFR</b>     | Code of Federal Regulations  |
| <b>CSB</b>     | U.S. Chemical Safety and Hazard Investigation Board                              |
| <b>EIA</b>     | U.S. Energy Information Administration   |
| <b>FOSV</b>    | full-opening safety valve  |
| <b>IADC</b>    | International Association of Drilling Contractors                                |
| <b>JSA</b>     | Job Safety Analysis  |
| <b>LEL</b>     | lower explosive limit  |
| <b>LLC</b>     | Limited Liability Corporation  |
| <b>NFPA</b>    | National Fire Protection Association   |
| <b>OSH</b>     | Occupational Safety and Health   |
| <b>OSHA</b>    | Occupational Safety and Health Administration                                    |
| <b>PSI</b>     | pounds per square inch (lower case), or Process Safety Information (if all caps) |
| <b>PSIG</b>    | pounds per square inch gauge   |
| <b>PSM</b>     | Process Safety Management  |
| <b>RAGAGEP</b> | Recognized and Generally Accepted Good Engineering Practice                      |

## GLOSSARY

The terms listed below are *emphasized* in the report at first usage. NOTE: unless otherwise noted, all definitions are taken from Schlumberger's Energy Glossary at <https://glossary.slb.com/en/>, Some of the definitions have been modified for clarity.

**Artificial lift** – Any system that adds energy to the fluid column in a wellbore with the objective of initiating and improving production from the well.

**Blowout** – Uncontrolled flow of formation fluids from a well.

**Brine** – A water-based solution of inorganic salts used as a well-control fluid during the completion and workover phases of well operations.

**Casing** – Large-diameter pipe inserted into a wellbore and cemented in place.

**Casing Valve** – A valve installed on a tubing head (or casing head) to provide access to the casing annulus.

**Cellar** – A dug-out area, possibly lined with wood, cement or very large diameter thin-wall pipe, located below the rig.

**Completion interval** – A section within the well that is prepared to permit the production of fluids from the well [1].<sup>a</sup>

**Downhole pump** – An artificial lift pumping system component connected to the bottom of a rod string that contains a plunger and valve assembly that converts reciprocating motion to vertical fluid movement.

**Formation** – A distinctive geological layer of rock.

**Formation damage** – A general term to describe the reduction in permeability to the area of a reservoir near the wellbore.

**Formation water** – Water that occurs naturally within formation pores.

**Hydrostatic pressure** – The pressure produced by the column of fluid in the wellbore.

**Joint** – A single length of pipe, usually referring to drillpipe, casing, or tubing.

**Kick** – Influx of reservoir fluid, liquid or gas, into the wellbore during drilling or workover [1].

**Lifting sub** – A short piping component that is temporarily connected to the top of an assembly that is to be lifted vertically.

---

<sup>a</sup> From the IADC Glossary

**Measured depth (MD)** – The length of the wellbore, as if determined by a measuring stick.

**Normal pressure** – Reservoir pressure equal to the pressure exerted by a vertical column of water with salinity normal for the geographic area [1]

**Overbalance (as in overbalanced well)** – The amount by which pressure exerted by the hydrostatic pressure of fluid in the wellbore exceeds formation pressure [1].

**Overpressure (as in overpressured reservoir)** – Subsurface pressure that is abnormally high, exceeding the hydrostatic pressure of formation water at a given depth.

**Pumping unit** – An artificial lift pumping system surface component consisting of a beam and crank assembly, creating a reciprocal motion in a rod string that connects to the downhole pump.

**Reservoir pressure** – The pressure of fluids within pores of the reservoir, or formation rock. Reservoir pressure is measured under static, non-flowing conditions [1].

**Rig floor** – Component of a workover rig where the rig crew conducts operations.

**Rod string** – The entire length of sucker rods (also called rods), which consists of single rods screwed together. The rod string serves as a mechanical link from the pumping unit on the surface to the downhole pump near the bottom of the well [2].

**Shut-in (tubing or casing) pressure** – The surface force per unit area exerted at the top of a wellbore when it is closed. The shut-in pressure may be zero, indicating that any open formations are effectively balanced by the hydrostatic column of fluid in the well. If the pressure is zero, the well is considered to be dead, and can normally be opened safely to the atmosphere.

**Stabbing valve** – A valve, generally kept on the rig floor, that is connected to piping in the event that the well starts to flow (also known as a safety valve).

**String** – An assembled length of rods, casing, or tubing.

**Tubing** – A wellbore pipe used to produce reservoir fluids.

**Tubing hanger** – A device attached to the topmost tubing joint in the wellhead to support the tubing string. The tubing hanger typically is located in the tubing head, with both components incorporating a sealing system to ensure that the tubing conduit and annulus are hydraulically isolated.

**Tubing head** – A wellhead component that supports the tubing hanger.

**Tubing joint** – A single length of the pipe that is assembled through which oil (or gas) will be produced from a wellbore. Tubing joints are generally around 30 feet in length.

**Underbalance (as in underbalanced well)** – The amount by which formation pressure exceeds pressure exerted by the hydrostatic pressure of fluid in the wellbore [1].

**Underpressure (as in underpressured reservoir)** – Reservoir pressure less than normal pressure.

Underpressure is common in areas that have had hydrocarbon production.

**Well control** - Methods used to minimize the potential for the well to flow or kick and to maintain control of the well in the event of flow or a kick [1].

**Wellbore** – The drilled hole, including the cased and uncased portions of the well.

**Wellhead** – The system of spools, valves, and assorted adapters that provide pressure control of a production well.

**Workover** – The repair or stimulation of an existing production well for the purpose of restoring, prolonging, or enhancing the production of hydrocarbons.

**Workover fluid** – A well-control fluid that is used during workover operations.

**Workover rig** – A mobile, self-propelled rig used to perform workover operations, such as pulling and installing well hardware.<sup>a</sup>

---

<sup>a</sup> From California Air Resources Board (<https://ww2.arb.ca.gov/sites/default/files/classic/msprog/ordiesel/faq/faqworkoverrig.pdf>)

The January 29, 2020, well blowout at the Wendland 1-H well fatally injured three people:

Windell “Jock” Beddingfield, Brian Maldonado, and Bradley Hendrix



## EXECUTIVE SUMMARY

On January 29, 2020, at approximately 3:00 p.m., the Daniel H. Wendland 1-H well (“Wendland 1-H well”), located in Burleson County, Texas and operated by Chesapeake Operating, L.L.C. (Chesapeake), experienced a loss of *well control* that resulted in a *blowout* of the well. Oil and gas escaped the well, and within seconds, found an ignition source, resulting in a flash fire in the vicinity of the well that fatally injured three contract workers and seriously injured another. One of the workers, who had been working close to the release point, suffered fatal burn injuries and died at the incident site. Two others suffered serious burn injuries and later died from their injuries. A fourth worker also suffered serious burn injuries but survived. All of the injured personnel were contract workers from either Eagle PCO LLC (Eagle) or CC Forbes Energy Services (Forbes). At the time of the incident, eleven contractors were working at the Wendland 1-H well site.

At the time of the incident, contract workers from Eagle were in the process of installing a new *tubing head* as part of a *workover* operation. Workers from Forbes, who provided the *workover rig*, were near the Wendland 1-H well preparing for their follow-on task of installing *tubing* in the well. Following the blowout, the ensuing flash fire destroyed the workover rig and several nearby vehicles, resulting in an estimated \$1 million in property damage in addition to the fatalities and serious injuries.

The Caldwell Volunteer Fire Department, Texas Department of Public Safety, and others responded to the incident.

## SAFETY ISSUES

The CSB’s investigation identified the safety issues below.

- **Well Planning.** At the time of the incident, industry guidance stated that companies should plan for well control prior to performing workover operations. Well planning procedures from industry guidance included gathering well information, analyzing the information to predict potential hazards, and formulating contingency plans to address these hazards. Chesapeake’s well control policies did not incorporate this guidance, and Chesapeake did not adequately review the past history of the Wendland 1-H well, which would have indicated previous well control issues. A review of the well information, conducted in accordance with industry guidance, could have resulted in the preparation of well control procedures to properly isolate the hydrocarbons from the surface activity. ([Section 4.1](#))
- **Well Control for Completed Wells in Underpressured Reservoirs.** Prior to installing the new tubing head, Chesapeake’s contractors pumped 50 barrels (bbls) of 10-pound-per-gallon (ppg) *brine* with the intent of providing *hydrostatic pressure* against the *formation*. The contractors also relied on open surface valves as mechanical well control barriers. The intended well control barriers were ineffective in preventing the loss of well control and subsequent blowout. Industry guidance does not provide reliable well control methods for completed wells in *underpressured* reservoirs. Further, existing regulations do not require the implementation and maintenance of well control for onshore oil and gas operations. ([Section 4.2](#))

- **Ignition Source Management.** At the time of the incident, a mixture of flammable hydrocarbons released from the well and found an ignition source. Multiple potential ignition sources were identified in the vicinity of the open *wellbore*. Chesapeake's policies did not incorporate industry guidance recommending that companies should perform hazard assessments when locating ignition sources and atmospheric monitors near potentially flammable atmospheres. ([Section 4.3](#))
- **Federal Regulatory Safety Requirements.** The Occupational Safety and Health Administration (OSHA) has historically exempted onshore oil and gas well drilling and servicing from its Control of Hazardous Energy regulation at 29 Code of Federal Regulations (CFR) 1910.147 as well as its Process Safety Management (PSM) standard requirements under 29 CFR 1910.119. In addition, OSHA has not developed a separate standard to cover onshore oil and gas drilling and servicing operations. As a result, there are minimal regulations that govern onshore oil and gas drilling and servicing operations despite prior attempts to promulgate special rules for this industry. ([Section 4.4](#))

## CAUSE

The CSB determined that the cause of the Wendland 1-H well blowout was the lack of well planning regarding the implementation of well control. Insufficient industry guidance regarding well control for completed wells in underpressured reservoirs contributed to the blowout, resulting in ineffective well control practices for these types of wells. The attempted well control barriers were ineffective, resulting in the release of hydrocarbons that ignited upon finding an ignition source.

The CSB also determined that ineffective ignition source management contributed to the fire, resulting in three fatal injuries and one serious injury. The absence of regulations governing onshore oil and gas operations contributed to the incident, resulting in the failure to both effectively control hazardous energy and implement essential risk assessments that could have prevented this incident.

## RECOMMENDATIONS

### Previously Issued Recommendations Superseded in This Report

#### To the Occupational Safety and Health Administration

#### **2018-01-I-OK-R1 (from the Pryor Trust Fatal Gas Well Blowout and Fire report)**

Implement one of the three following options regarding regulatory changes:

- a. OPTION 1: Apply the Process Safety Management (PSM) standard (29 CFR 1910.119) to the drilling of oil and gas wells; or
- b. OPTION 2: Apply the Process Safety Management (PSM) standard (29 CFR 1910.119) to the drilling of oil and gas wells as in OPTION 1, and make the necessary modifications to customize it to oil and gas drilling operations; or
- c. OPTION 3: Develop a new standard with a safety management system framework similar to PSM that applies only to the drilling of onshore oil and gas wells that includes but is not limited to the following:

1. Detailed written operating procedures with specified steps and equipment alignment for all operations;
2. Written procedures for the management of changes (except replacements in kind) in procedures, the well plan, and equipment;
3. A risk assessment of hazards associated with the drilling plan;
4. A requirement to follow Recognized and Generally Accepted Good Engineering Practices (RAGAGEP);
5. Development of a Well Construction Interface Document between the operator and the drilling contractor prior to the commencement of drilling activities which at a minimum includes a bridging document and well plan specifying barriers and how to manage them;
6. The performance and documentation of flow checks using acceptable methods at defined points during the operation for a specified duration; and
7. A requirement for employee participation, similar to the Employee Participation requirement in the OSHA PSM standard.

*Superseded by 2020-04-I-TX-R4 to OSHA below.*

### **Recommendations Issued in This Report**

#### **To Chesapeake Operating, L.L.C.:**

##### **2020-04-I-TX-R1**

Develop or revise policies incorporating the recommendations of API RP 59 regarding well planning, specifically the inclusion of well history review in conjunction with workover well control planning.

#### **To the American Petroleum Institute:**

##### **2020-04-I-TX-R2**

Publish the following information in an appropriate document such as API RP 59 *Recommended Practice for Well Control Operations*:

1. A focused discussion on practices applicable to workover operations, including completed wells in underpressured reservoirs. Include well control methods applicable to workover operations, such as using continuous fluid addition, viscous fluids, bridging solids, and mechanical plugs. Also include a discussion on the well control challenges and hazards specific to workover operations;
2. *Stabbing valves* should not be considered as well control barriers for workover operations; and

3. Every well should be considered to have potential to flow, and therefore, should have two well control barriers, one of which should be a preventative barrier.

**To the U.S. Occupational Safety and Health Administration:**

**2020-04-I-TX-R3**

Remove the exemption for oil and gas drilling and well servicing from the Control of Hazardous Energy standard (29 CFR 1910.147) and expand its applicability to cover oil and gas production and workover operations.

**2020-04-I-TX-R4**

Promulgate a new standard with prescriptive requirements, similar to the Control of Hazardous Energy standard, as well as a performance-based safety management system framework, similar to the OSHA Process Safety Management (PSM), that applies to the drilling, production, and servicing/workover activities surrounding onshore oil and gas wells. At a minimum, this standard should include the following:

1. Prescriptively address requirements for primary and secondary barriers for well control;
2. Detailed written drilling, production, and servicing procedures with specified steps and equipment alignment for all operations;
3. Management of change requirements (except replacements in kind) that, at a minimum, address procedures, the well plan, and equipment;
4. A risk assessment of hazards associated with the drilling, production, and servicing/workover plans;
5. A requirement to follow Recognized and Generally Accepted Good Engineering Practices (RAGAGEP);
6. Development of a Well Construction Interface Document between the operator and the drilling contractor prior to the commencement of drilling and servicing activities and an equivalent document for production and workover contractors which, at a minimum, includes a bridging document and well plans specifying barriers and how to manage them;
7. The performance and documentation of flow checks using acceptable methods at defined points during the operation for a specified duration;
8. A requirement for employee participation, similar to the Employee Participation requirement in the OSHA PSM standard;
9. A requirement for maintaining critical well information, similar to the Process Safety Information requirement in the OSHA PSM standard, which at a minimum includes well history and documented well control methods during workovers;
10. A requirement for analyzing and assessing the hazards during all phases and steps for well servicing, similar to the Process Hazard Analysis requirement in the OSHA PSM standard;

11. A requirement for developing, executing, communicating, and maintaining procedures for drilling, production, and servicing operations on a well, similar to the Operating Procedures requirement in the OSHA PSM standard; and
12. The documentation of well control plans for drilling, production, and servicing/workover operations for a well utilizing acceptable methods for monitoring the effectiveness of well control methods.

# 1 BACKGROUND

## 1.1 COMPANIES INVOLVED AT THE TIME OF THE INCIDENT

### 1.1.1 CHESAPEAKE OPERATING, L.L.C.

Chesapeake Operating, L.L.C. (Chesapeake) is an oil and gas extraction company headquartered in Oklahoma City, Oklahoma. At the time of the incident, Chesapeake's parent company, Chesapeake Energy Corporation, owned assets in Texas, Louisiana, Wyoming, and Pennsylvania. Chesapeake became the operator of the Daniel H. Wendland 1-H well ("the Wendland 1-H well") in June 2019. In January 2023, Chesapeake announced plans to sell some of its assets in the Brazos Valley, which included the Wendland 1-H well, to WildFire Energy LLC.

### 1.1.2 SDS PETROLEUM CONSULTANTS, L.L.C.

SDS Petroleum Consultants, L.L.C. (SDS Petroleum) advertises project management, wellsite supervision, and engineering services for companies. For the work conducted on the Wendland 1-H well in January 2020, SDS provided an Onsite Supervisor, who acted as Chesapeake's on-site representative.

### 1.1.3 CC FORBES, LLC

CC Forbes, LLC (Forbes) provided the *workover rig* and a crew of five rig workers for the Wendland 1-H well work on January 29, 2020. According to the State of Texas, Forbes' existence was terminated on or around August 16, 2022.

### 1.1.4 EAGLE PCO LLC

Eagle PCO LLC (Eagle) was a service company that provided, among other things, *wellhead* sales and installation services. For the well work on January 29, 2020, Eagle provided a work crew to replace the existing *tubing head*. At the time of the incident, Eagle had four employees at the well site. On or around November 6, 2020, Eagle filed for Chapter 11 bankruptcy, and its bankruptcy case was closed on June 23, 2021.

### 1.1.5 A&L HOT OIL SERVICE INC.

A&L Hot Oil Service Inc. (A&L) is advertised as a company that performs "oilfield production treating & maintenance on existing wells...." For the well work in January 2020, A&L provided one operator with a truck used to pump fluid into the Wendland 1-H well.

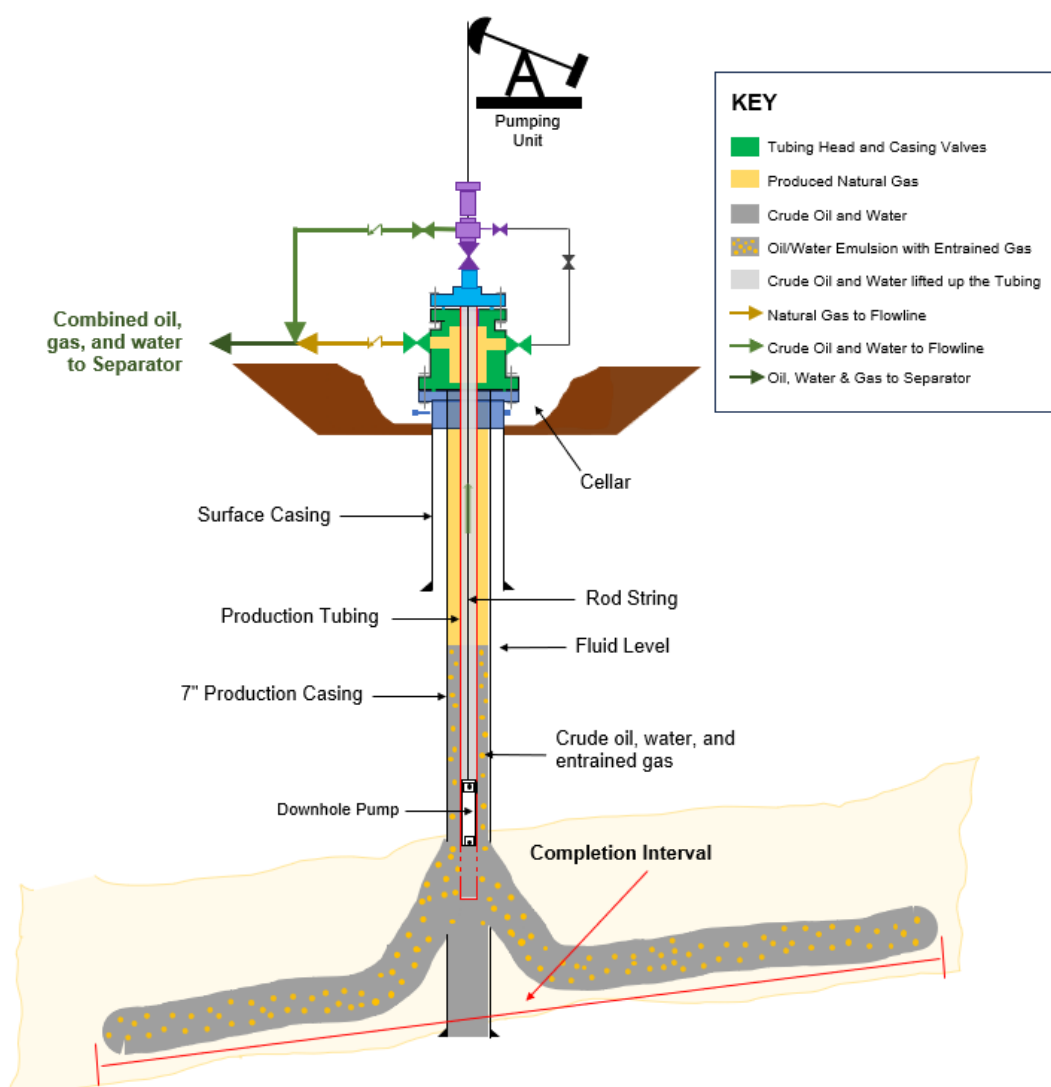
### 1.1.6 WORKOVER BEGINNING JANUARY 27, 2020

At the time of the incident, the Wendland 1-H well was undergoing *workover* operations. The workover was managed by a Chesapeake employee, and the work at the well site was performed by the contractors identified

in this section. Chesapeake employees and representatives were in communication with on-site contract personnel via Microsoft Teams and cell phones during workover operations. At the time of the incident, eleven contractors were working at the Wendland 1-H well site.

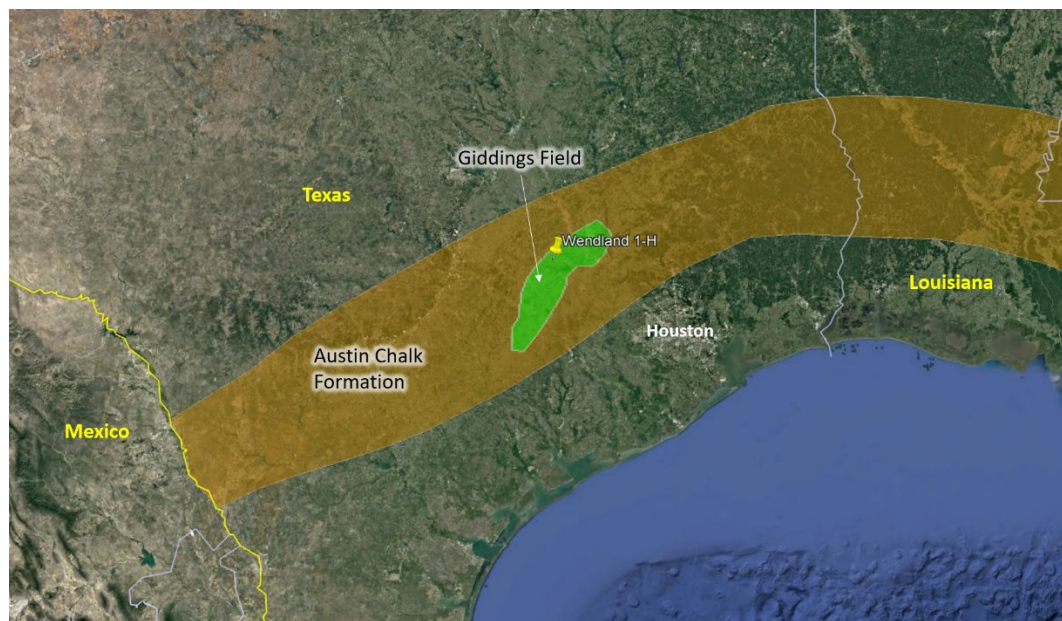
## 1.2 DANIEL H. WENDLAND 1-H WELL

The Wendland 1-H well was initially drilled in 1980 by Columbia Gas Development Corporation (Columbia). The Wendland 1-H well is classified as an oil well, but it also produced gas. A schematic of the Wendland 1-H well is shown in **Figure 1**. There have been multiple operators of the Wendland 1-H well since the original well was drilled by Columbia: Union Pacific Resources Company, beginning in June 1996; RME Petroleum Company, beginning in February 2001; Anadarko E&P Company LP, beginning in December 2002; Anadarko E&P Onshore LLC, beginning in January 2013; and Wildhorse Resources Management Company, LLC, beginning in July 2017. In June 2019, Chesapeake became the operator of record for the Wendland 1-H well.



**Figure 1.** Schematic of the Wendland 1-H well. (Credit: CSB)

At the time of the incident, the Wendland 1-H well was operated by Chesapeake and was located on private land approximately 91 miles northwest of Houston<sup>a</sup> (**Figure 2**).



**Figure 2.** Location of the Wendland 1-H well and its position within the Giddings Field and the Austin Chalk *formation*. (Credit: Google Earth, annotation by CSB with information derived from GoHaynesvilleShale.com [3])

### 1.3 OIL AND GAS PRODUCTION IN THE UNITED STATES

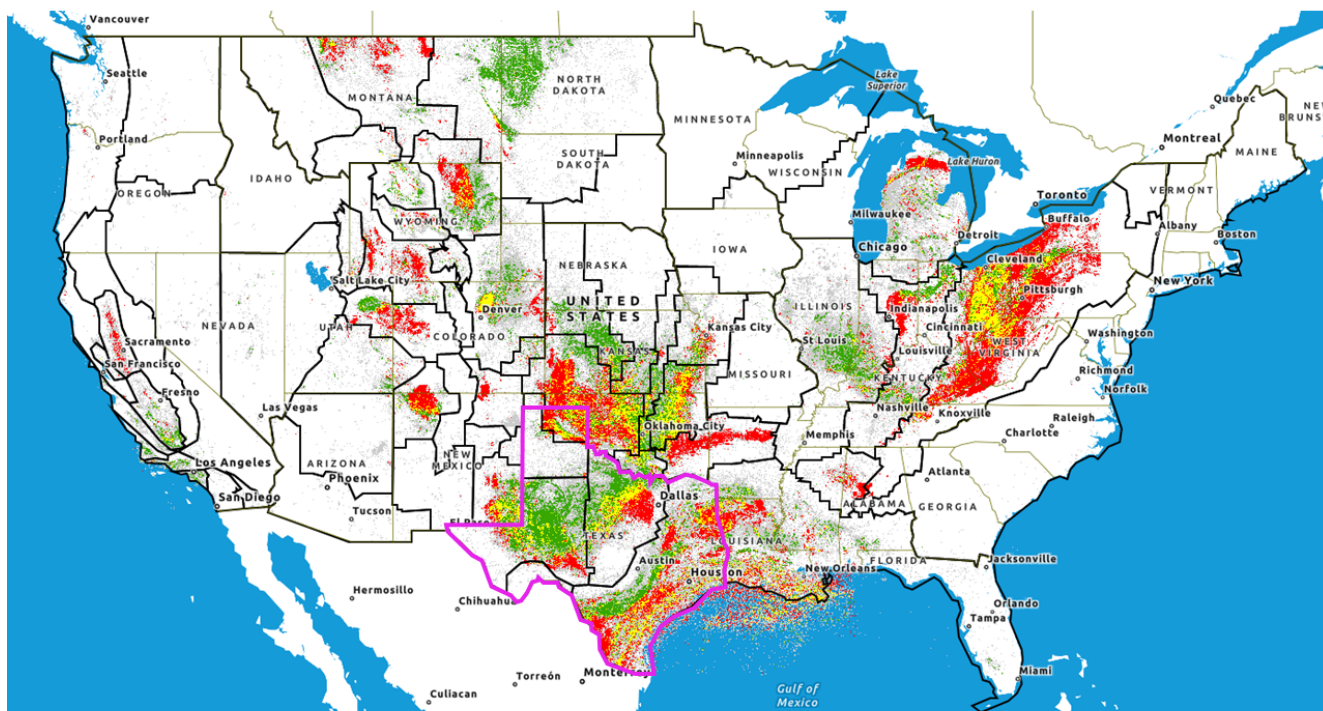
In an effort to assist in energy policy decisions and to increase public awareness of energy in the United States, the U.S. Energy Information Administration (EIA) “collects, analyzes, and disseminates independent and impartial energy information [4].” In December 2022, the EIA published a report titled “The Distribution of U.S. Oil and Natural Gas Wells by Production Rate [5].” Appendix B of the EIA report shows that in 2021, there were 318,256<sup>b</sup> oil wells in the United States (see **Figure 3**) that produced, on average, 15 barrels or less of oil per day, with more than one-third of these wells (126,351) located in the state of Texas [5, pp. B22-B35].<sup>c</sup>

<sup>a</sup> Distances obtained using Google Earth Pro.

<sup>b</sup> This includes 2,423 offshore oil wells in Federal waters.

<sup>c</sup> Texas leads the nation both in the number of oil wells and the amount of annual oil production (1.466 billion barrels).

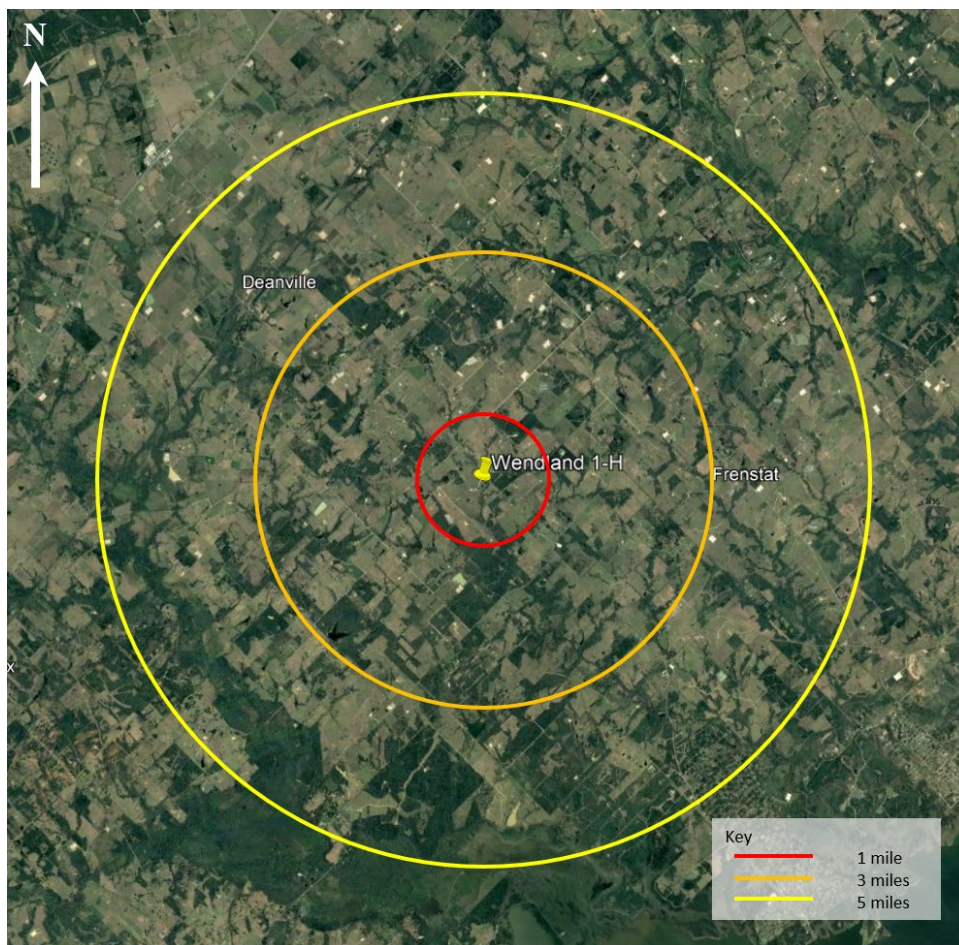




**Figure 3.** U.S. map showing oil and gas wells, with the state of Texas outlined in magenta. Oil wells are depicted by green dots, gas wells by red dots, and combination oil and gas wells by yellow dots. (Credit: United States Geological Survey, annotation by CSB).

## 1.4 DESCRIPTION OF SURROUNDING AREA

**Figure 4** shows the Wendland 1-H well and depicts the area within one, three, and five miles of the well site. Summarized demographic data for U.S. Census Bureau Tract 9702.01 containing the Wendland 1-H well, located in a rural area, are shown below in **Table 1**. There were 1,715 people residing in 844 housing units, most of which are single-family units, within the census tract containing the Wendland 1-H well.



**Figure 4.** Overhead satellite image of the Wendland 1-H well and the surrounding area (Credit: Google Earth, annotation by CSB)

**Table 1.** Summarized demographic data for Census Tract 9702.01, where the Wendland 1-H well was located. (Credit: CSB using data obtained from Census Reporter)

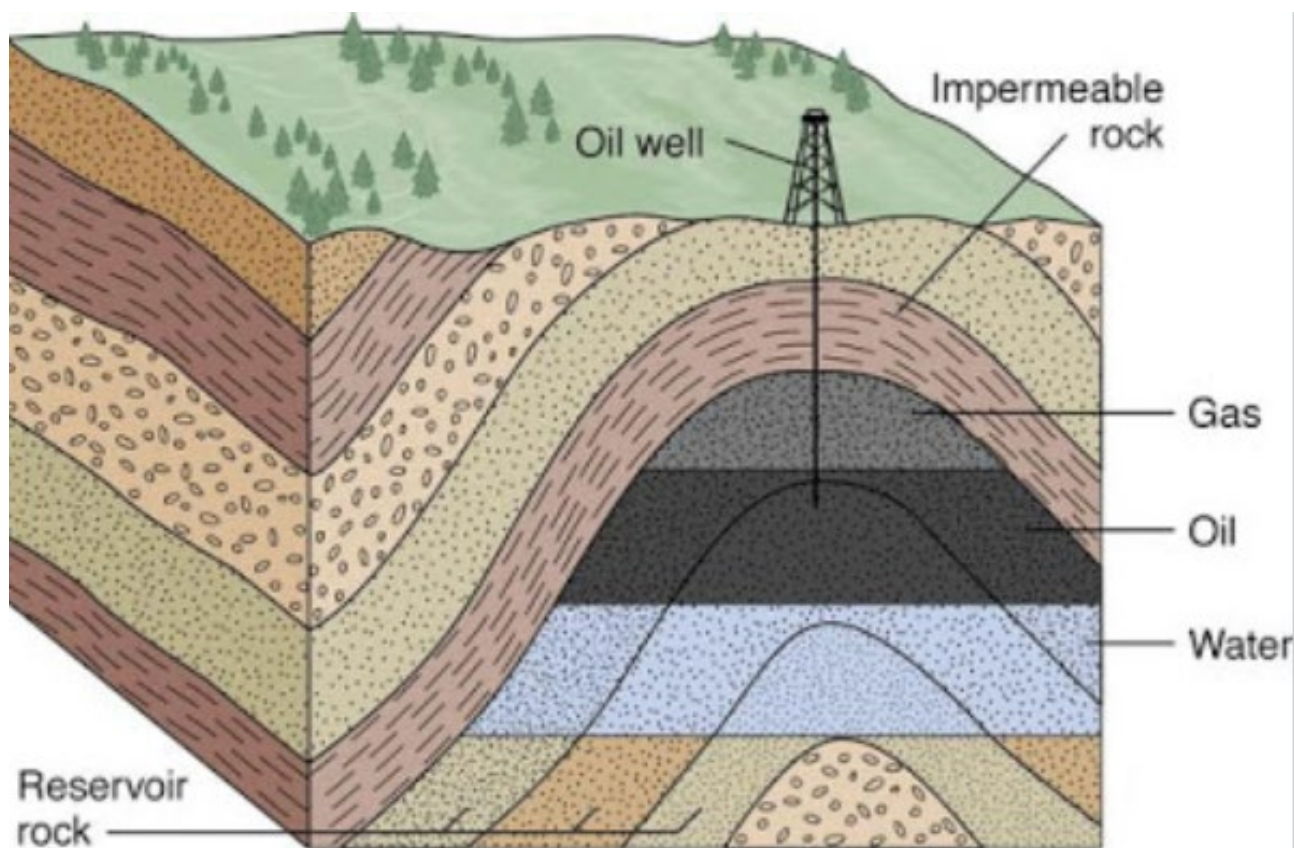
| Population | Race and Ethnicity |     | Per Capita Income     | Percent Poverty | Number of Housing Units | Types of Housing Units |     |
|------------|--------------------|-----|-----------------------|-----------------|-------------------------|------------------------|-----|
|            |                    |     |                       |                 |                         |                        |     |
| 1,715      | White              | 65% | \$32,179 <sup>a</sup> | 5.8%            | 844                     | Single Unit            | 64% |
|            | Hispanic           | 24% |                       |                 |                         | Mobile Home            | 36% |
|            | Black              | 9%  |                       |                 |                         | Mobile Home            | 36% |
|            | Multi-racial       | 2%  |                       |                 |                         |                        |     |

<sup>a</sup> Census Reporter reports that Burleson County’s per capita income was \$32,707 [34]. The Census Bureau reports that the overall annual per capita income for the United States from 2017-2021 was \$37,638 [35].

## 1.5 OIL PRODUCTION CONCEPTS AND TERMINOLOGY

### 1.5.1 PETROLEUM RESERVOIR BASICS

A petroleum reservoir, also called oil and gas reservoir (see **Figure 5**), is a subsurface accumulation of hydrocarbons contained in porous or fractured rock formations. The hydrocarbons are trapped by overlying impermeable layers of rock [6].



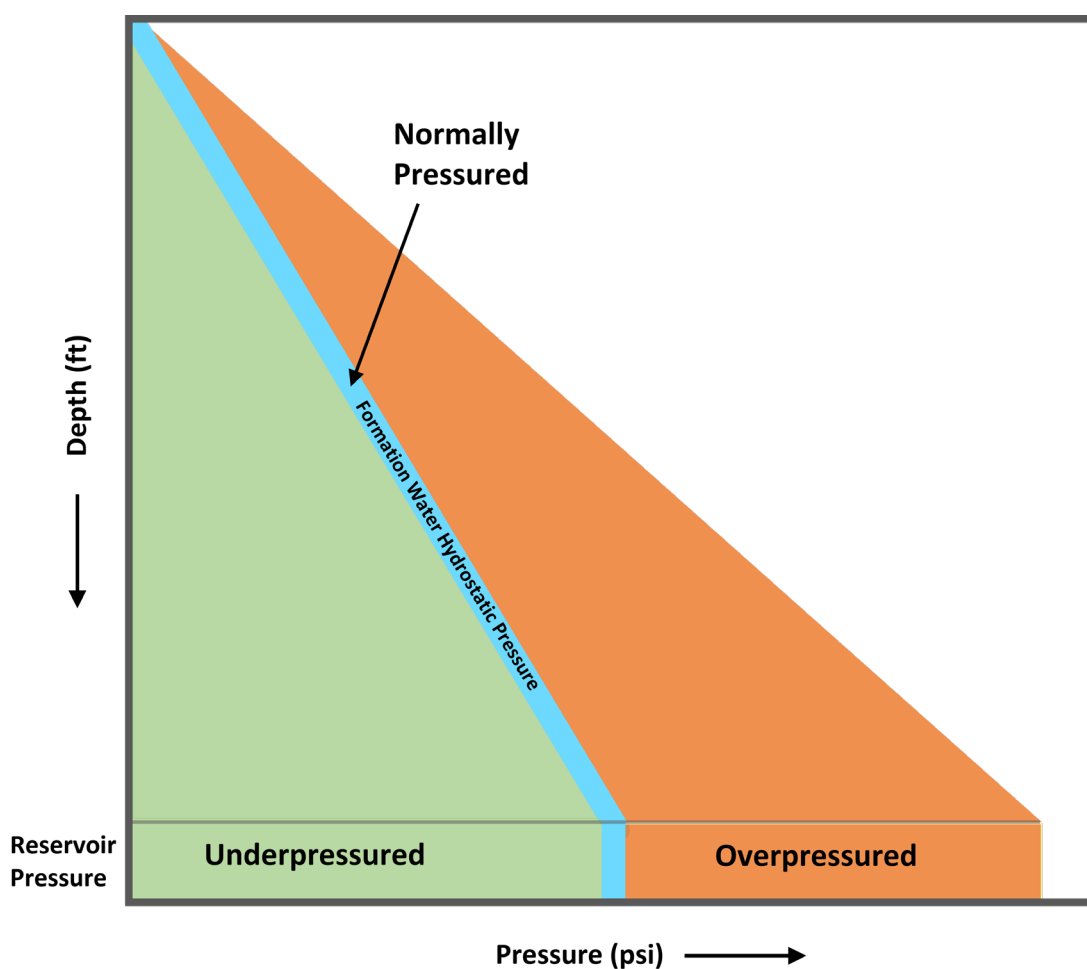
**Figure 5.** Schematic depicting a petroleum reservoir (Credit: University of Calgary, Energy Education [6])

Wells are drilled and produced to extract oil and gas from the reservoir [7]. As the well is drilled, *casing* is placed into the drilled hole and cemented in place [8]. The casing is large diameter pipe that serves as the *wellbore* [9]. Once the well has reached the depth of the productive formation, the well is *completed* in order to provide an open path between the wellbore and the oil or gas reservoir [10].

### 1.5.2 RESERVOIR PRESSURE AND HYDROSTATIC PRESSURE

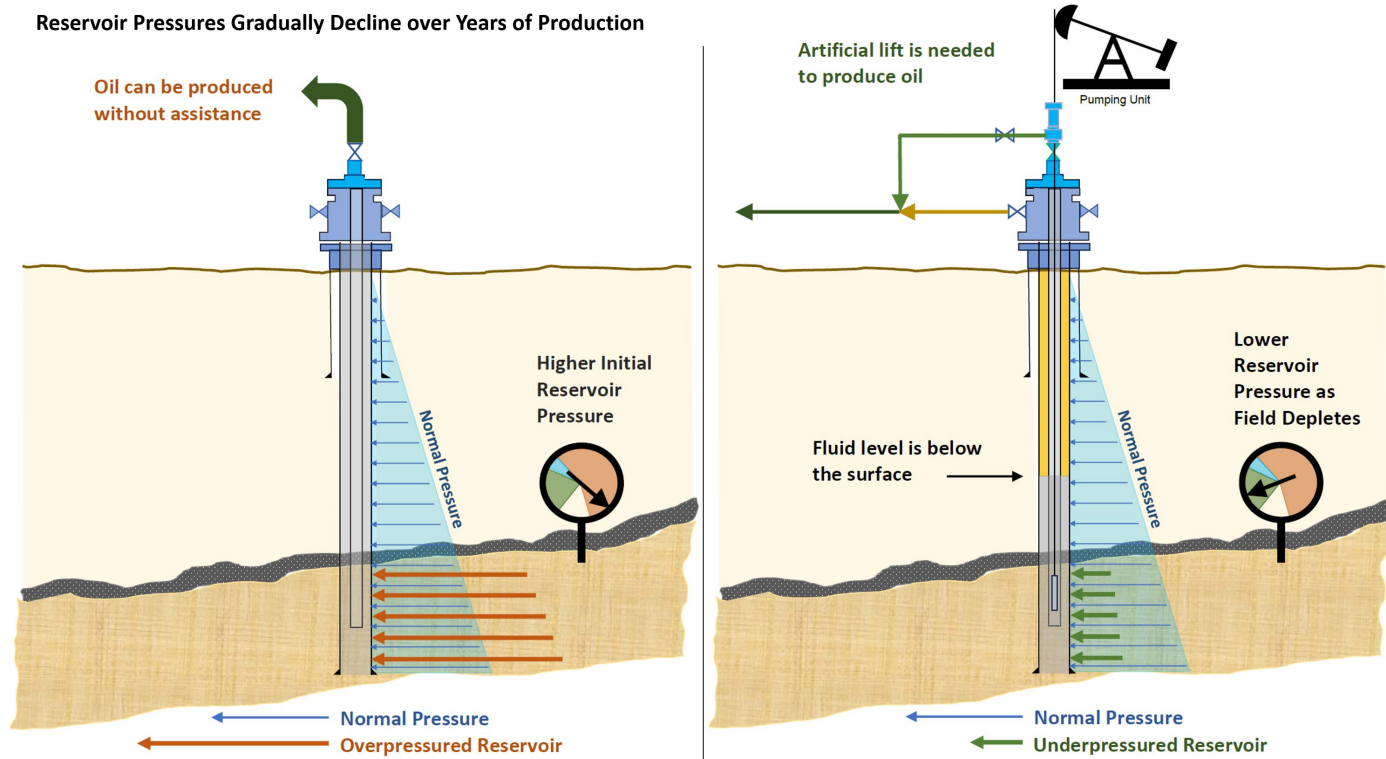
The *reservoir pressure* is the pressure of fluid in the pore spaces within formation rock [11, 12] and is measured under static, non-flowing conditions [1].

Reservoir pressure for a given reservoir is characterized as either *overpressured* [13], *normally pressured* [1], or *underpressured* [13]. This characterization depends on the relationship of the reservoir pressure to normal *hydrostatic pressure* (see **Figure 6**). Hydrostatic pressure is defined as the pressure that exists at any point in a column of fluid, such as in a wellbore, due to the weight of the vertical column of fluid above that point [1]. Referring to **Figure 6**, in normally pressured reservoirs, the reservoir pressure is equal to the hydrostatic pressure of *formation water* measured at the reservoir depth [1]. In an overpressured reservoir, the reservoir pressure exceeds the hydrostatic pressure of a column of formation water [13].



**Figure 6.** Graphical representation of reservoir pressure characterizations. (Credit: CSB)

Newly discovered reservoirs may be overpressured (see **Figure 7**), meaning that wells drilled and completed into these formations will flow to the surface unassisted [13]. Over time, as oil and gas are produced from the reservoir, the pressure gradually decreases [13]. When the reservoir pressure is decreased to the point that the reservoir is underpressured, the well will no longer naturally flow to the surface on its own [14, p. 223]. The reservoir pressure in these underpressured reservoirs is too low to support a column of fluid to the surface (see **Figure 7**). An *artificial lift* method, such as using a *pumping unit* with a *downhole pump* (see **Figure 7**, right side), may be added, which allows continuing production from wells in underpressured reservoirs [12]. Being in an underpressured reservoir, the Wendland 1-H well produced oil via artificial lift using a pumping unit with a downhole pump.



**Figure 7.** Schematic showing overpressured reservoir (left) versus underpressured reservoir (right) (Credit: CSB)

### 1.5.3 WELL WORKOVERS

During the life of producing oil and gas wells, they occasionally require routine services or additional well work known as *workovers*. During well workovers, remedial work (i.e., maintenance or repair) is done on the well that may involve repairs or other procedures to increase the production flow rate [1]. Workovers are performed using a *workover rig* (see **Figure 8**). The well is shut in,<sup>a</sup> and production equipment, such as the pumping unit, is isolated and certain equipment is removed to allow the workover rig<sup>b</sup> to prepare for the well work.

<sup>a</sup> When a well is “shut in,” the flow paths for formation fluids to the surface are closed [41].

<sup>b</sup> The workover rig was not being used at the time of the January 29, 2020, incident.

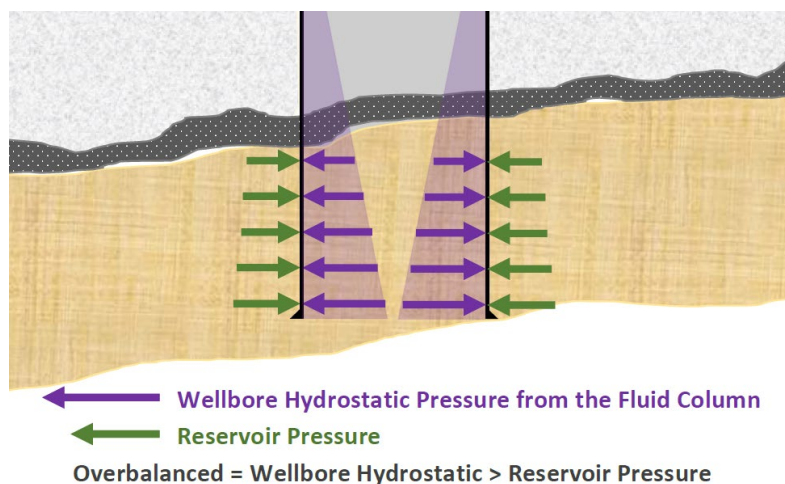


**Figure 8.** Example workover rig with mast extended (left) and mast stowed (right). (Credit: Dragon Products [left] and World Rigs [right])

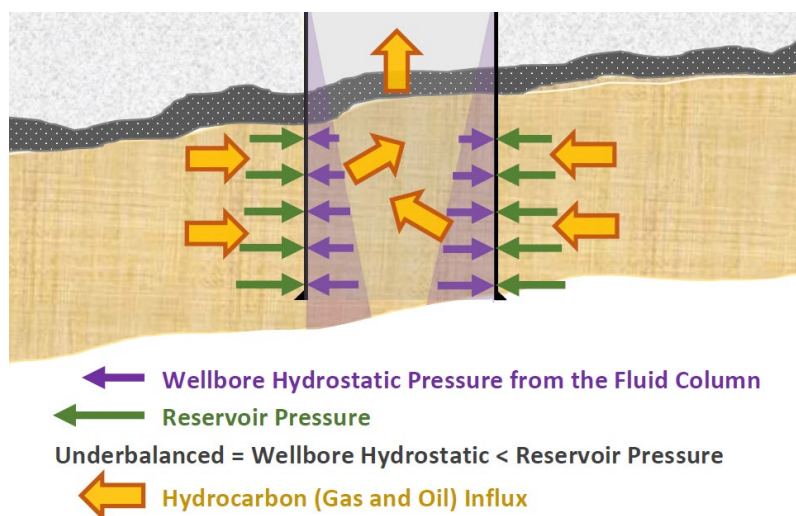
#### 1.5.4 WELL CONTROL

*Workover fluids* are used in conjunction with the workover procedure to provide *well control*, which is discussed in the next section [15]. Well control [1] refers to methods used to minimize the potential for an influx of fluids into the wellbore from the formation, also called a *kick* [1], which can lead to uncontrolled flow to the surface, also called a *blowout* [1]. According to the American Petroleum Institute (API), a kick will occur if the reservoir pressure exceeds the wellbore pressure and sufficient permeability exists within the reservoir [16, p. 32].

When the pressure exerted by the hydrostatic fluid column in the wellbore exceeds the reservoir pressure, the well is *overbalanced* (see **Figure 9**) [1], resulting in a hydrostatic barrier that prevents formation fluids from entering the wellbore [16, p. 7]. When the hydrostatic pressure in the wellbore is less than the reservoir pressure, the well is *underbalanced*, and reservoir fluids can flow into the wellbore (see **Figure 10**) [1].



**Figure 9.** Graphical depiction of overbalanced wellbore. (Credit: CSB)



**Figure 10.** Graphical depiction of underbalanced wellbore with resulting influx. (Credit: CSB)

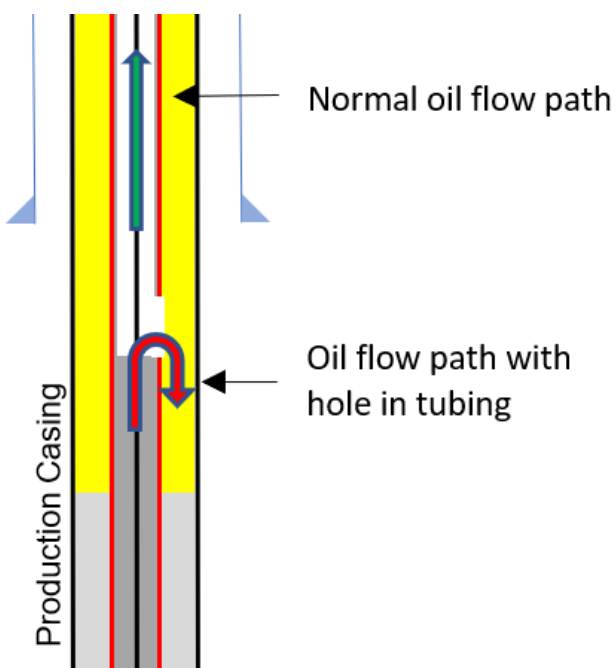
Well control is accomplished by establishing and maintaining barriers to protect against a hydrocarbon blowout [16, p. 54]. The Center for Chemical Process Safety (CCPS) provides the following definition of “barrier” that can apply to onshore oil and gas operations:

A control measure or grouping of controls that on its own can prevent a threat developing into a top event (prevention barrier) or can mitigate the consequences of a top event once it has occurred (mitigation barrier). A barrier must be effective, independent, and auditable [17, p. 31].

## 2 INCIDENT DESCRIPTION

### 2.1 WORKOVER PLANNING

In November 2019, Chesapeake suspected that a hole had formed in the *tubing* of the Wendland 1-H well due to the loss of oil production. Then, on November 26, 2019, Chesapeake discovered a possible hole in the tubing at a *measured depth* of 3,674 feet, preventing the well from producing oil (see **Figure 11**). The well stopped producing oil on November 20, 2019, and continued to produce natural gas until January 18, 2020. On January 26, 2020, the contract Onsite Supervisor from SDS Petroleum arrived at the well to prepare for the upcoming workover to repair the tubing.



**Figure 11.** Schematic showing the effect of a hole in the tubing on the flow of oil. (Credit: CSB)

The scope of the planned workover was, in part, to assess the tubing and replace one or more *tubing joints*, as necessary.

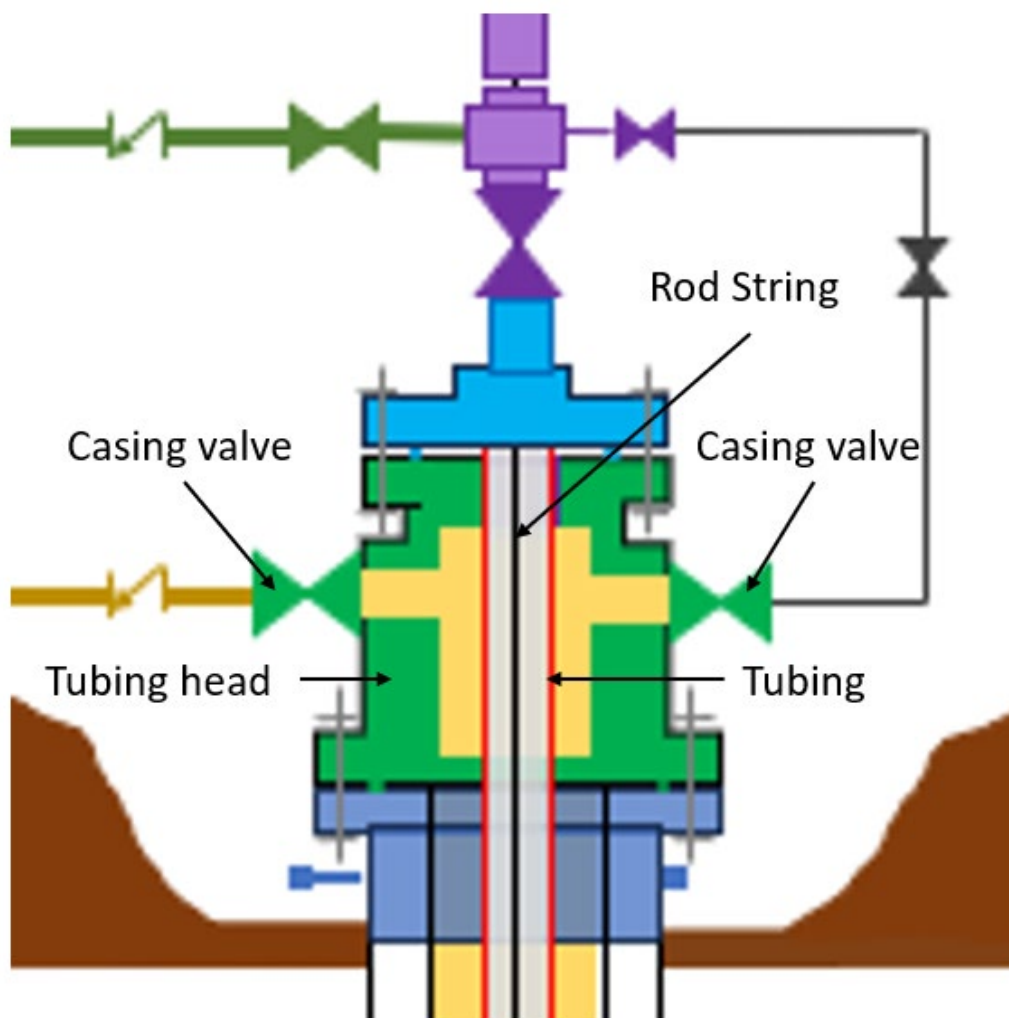
### 2.2 WORKOVER ACTIVITIES

On January 27, 2020, the Onsite Supervisor had a construction crew prepare the location for the workover rig to address excessive mud at the well site. Just before 10:00 a.m., after the workover rig arrived, the Onsite Supervisor held a Pre-Job Safety Assessment and reported a *shut-in tubing pressure* and *shut-in casing pressure* of 80 pounds per square inch gauge (psig) on the well. The Onsite Supervisor then had the hot oil



contractor from A&L<sup>a</sup> pump five barrels (bbls) of treated water into the well through the tubing to confirm the hole in the tubing. The Onsite Supervisor stated that they did not see a pressure increase in the tubing,<sup>b</sup> which indicated that the tubing was leaking.

The Onsite Supervisor then had A&L switch to pumping treated hot water, and A&L pumped an additional 20 bbls of treated hot water<sup>c</sup> into the well. After lunch, the workover rig crew from Forbes began pulling the *rod string* (see **Figure 12**) out of the wellbore. Before ending work for the day, the Onsite Supervisor had the hot oil contractor pump 45 more barrels of treated hot water into the well for paraffin removal.



**Figure 12.** Expanded view of surface equipment. (Credit: CSB)

<sup>a</sup> The job of the hot oil contractor was to pump water or brine into the well as needed.

<sup>b</sup> When brine was pumped into the tubing, the crew should have seen a rise in pressure once the fluid column in the tubing reached the surface.

<sup>c</sup> The purpose of using hot water was to remove paraffin, a waxy hydrocarbon compound, from the rod string.

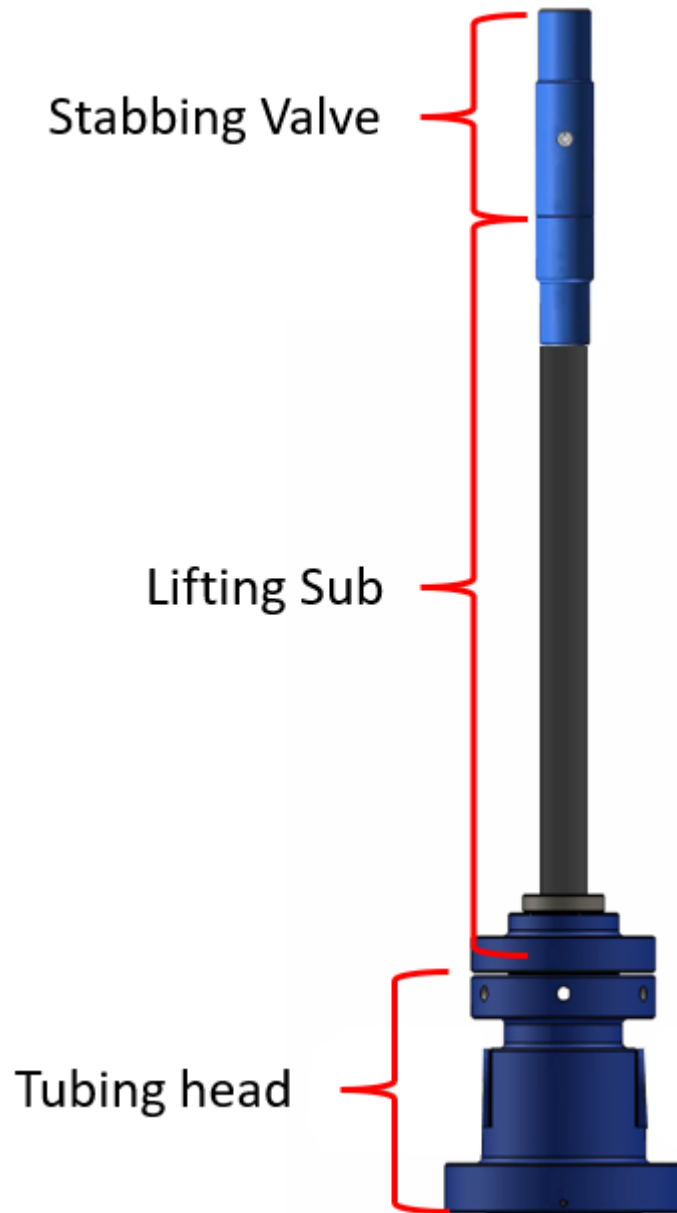
On Tuesday, January 28, 2020, the rig crew continued to pull out and inspect all of the rods. After the rig crew finished pulling out the rods, Chesapeake communicated a new task to change the existing tubing head to ensure the tubing head assembly, including the casing valves and connections, were rated to 5,000 pounds per square inch (psi). At around 2:45 p.m., the rig crew completed pulling out the rods and began to pull out and scan the tubing looking for signs of corrosion.

At around 8:30 a.m. on Wednesday, January 29, 2020, the Onsite Supervisor reported they had completed pulling the remaining tubing joints from the well and were digging out the *cellar* (see **Figure 1**) to access the tubing head (see **Figure 13**) for replacement.<sup>a</sup> The work crew, consisting of Forbes and Eagle workers, then installed a tubing head adapter, a *lifting sub*, and a *stabbing valve* (see **Figure 14** and **Figure 15**) on top of the existing tubing head to facilitate replacement.



**Figure 13.** Existing tubing head with one of the casing valves attached. (Credit: Chesapeake, annotation by CSB)

<sup>a</sup> The well cellar refers to “a stabilized excavation around the wellhead to provide space for equipment at the top of the wellbore.” The work crew used a high-pressure washer with vacuum to try and clean out the cellar, and they also dug it out with a shovel when the pressure washer was no longer effective.



**Figure 14.** Lifting assembly used to enable the workover rig to lift the tubing head (Credit: Eagle, annotation by CSB)



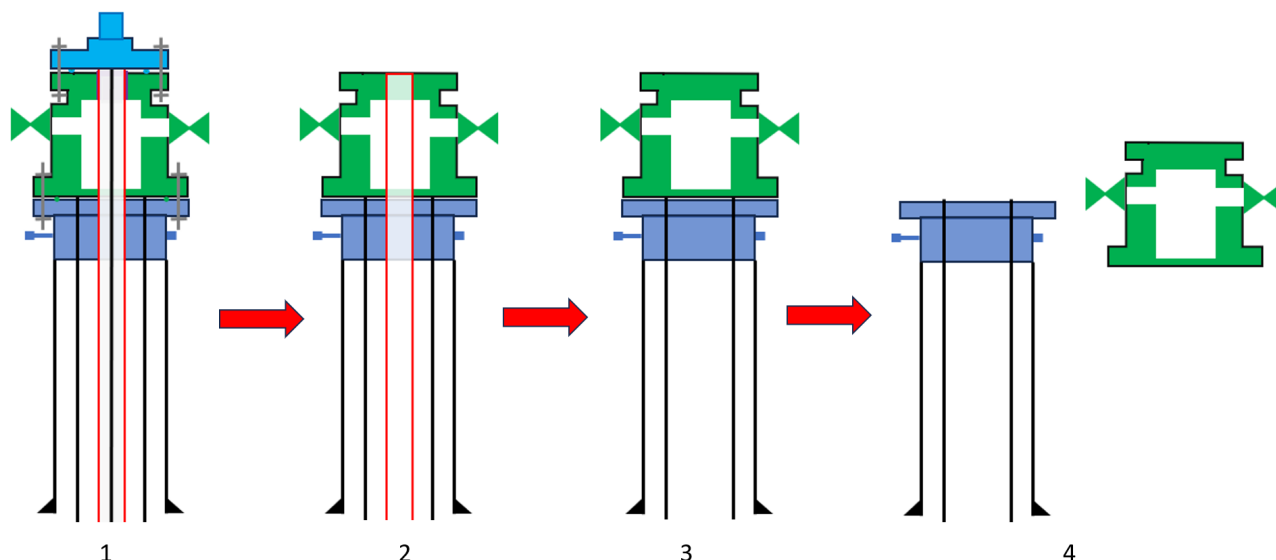
**Figure 15.** Stabbing valve and lifting sub. (Credit: CSB)

The Onsite Supervisor instructed A&L, the hot oil contractor, to pump an additional 50 bbls of 10-pound-per-gallon (ppg) brine<sup>a</sup> into the casing before removing the existing tubing head to establish a hydrostatic barrier. About 15 minutes after pumping the brine into the well, a “little puff” of gas came out of the well,<sup>b</sup> after which the Onsite Supervisor believed the well to be static, or non-flowing. **Figure 16** depicts the well schematics showing the work progression up to the point of removing the existing tubing head, described by the following:

<sup>a</sup> The CSB could not confirm the fluid quantities or densities.

<sup>b</sup> According to the Onsite Supervisor, it was normal to see some gas come out of the Wendland 1-H well after pumping fluid into the well.

(1) the surface equipment has been disconnected from the pumping unit and flow lines, (2) the rod string has been removed, (3) the tubing has been removed, and (4) the existing tubing head has been removed.



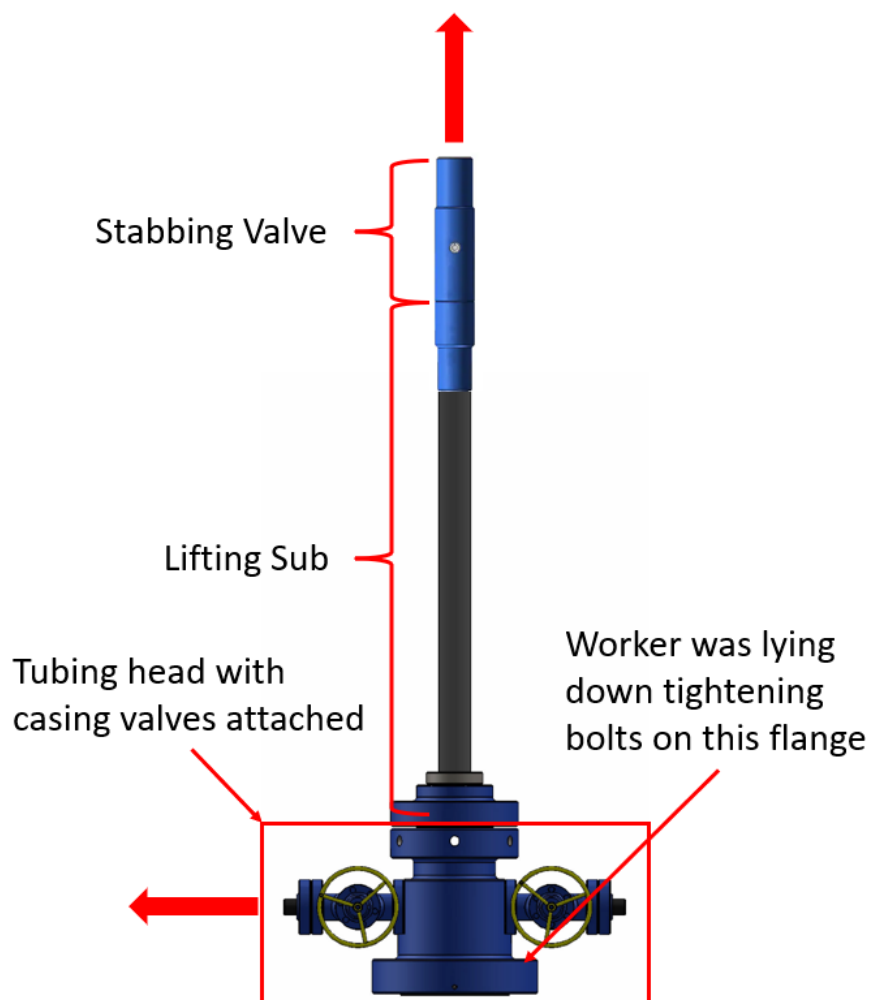
**Figure 16.** Well schematics showing the different configurations as the workover progressed. (Credit: CSB)

After removing the old tubing head, the work crew, likely consisting of Forbes and Eagle workers, then reinstalled the flange, ring, and lifting sub with shut-off valve on the top of the new tubing head and lifted the tubing head assembly onto the well. After hand-tightening all of the flange bolts, workers from Eagle torqued four of the bolts while the Onsite Supervisor remained at the well site. To torque the bolts on the new tubing head, Eagle workers used a remote-controlled torque wrench powered using an electric hydraulic pump (power pack). The new casing valves and the stabbing valve were left open throughout the installation and bolt-up.<sup>a</sup> These valves were intentionally left open due to concerns about experiencing well pressure while the tubing head was being installed.

## 2.3 WELL BLOWOUT AND FIRE

At about 3:00 p.m. on Wednesday, January 29, 2020, the installation crew from Eagle was in the process of torquing the bolts attaching the tubing head to the top casing flange when the well began releasing oil and gas through the open stabbing valve and casing valves, as depicted in **Figure 17**. One worker described feeling drops of oil followed by an “explosion” as the oil and gas released from the well. Shortly after the blowout began, the hydrocarbons ignited, engulfing the area around the well in flames.

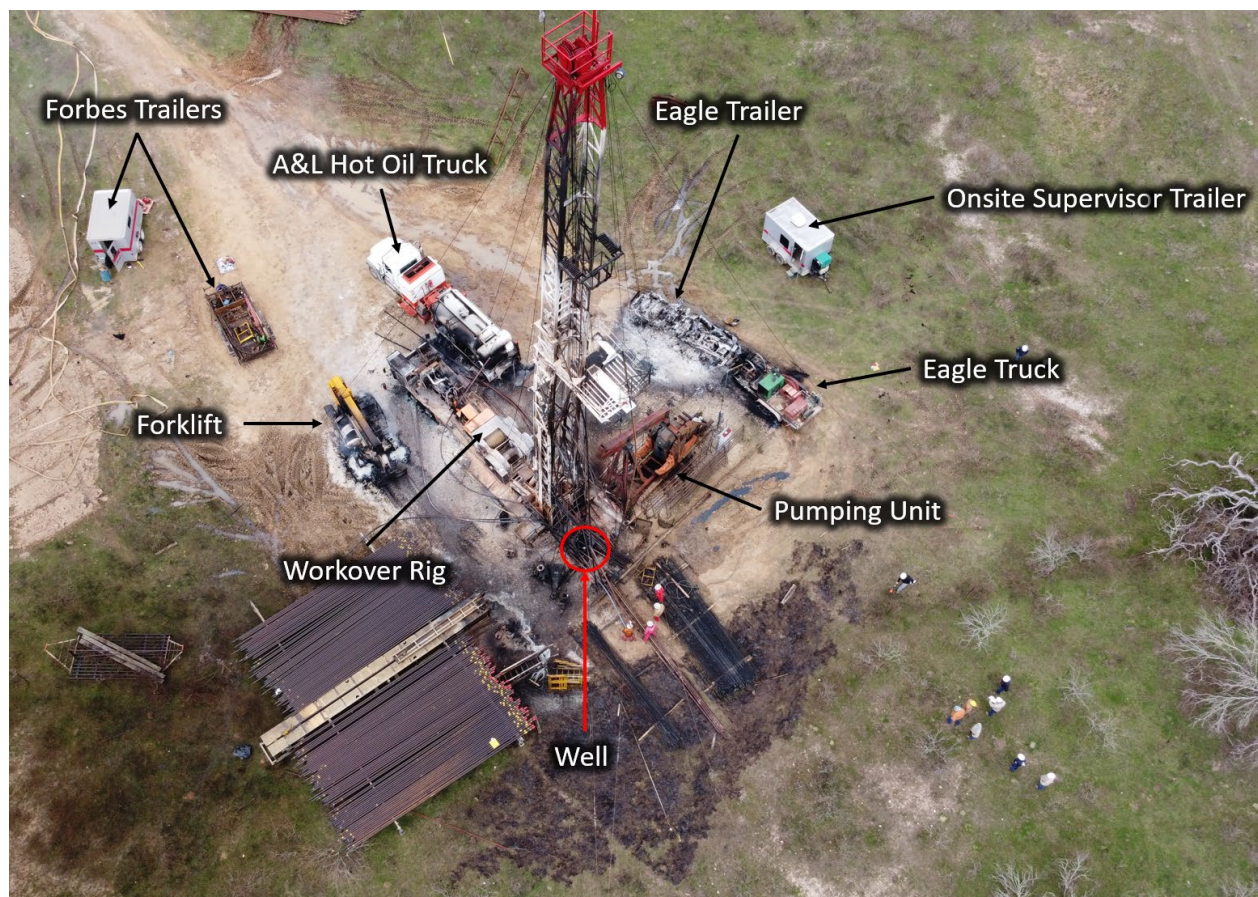
<sup>a</sup> One of the casing valves was plugged at the time of the incident. Although the casing valve was open, the plug prevented the flow of hydrocarbons through the valve.



**Figure 17.** Schematic showing the upper wellhead configuration at the time of the incident with the release points indicated. (Credit: Eagle, annotation by CSB)

## 2.4 EMERGENCY RESPONSE

After the blowout, the supervisor reported seeing workers evacuating from the well area. The supervisor noted that after arriving at the muster point and conducting an accountability check, one person was missing and three other workers were badly burned. Witnesses indicated that three Eagle personnel were working in the cellar at the time of the incident. **Figure 18** shows the locations of equipment once the fire was extinguished.



**Figure 18.** Diagram of equipment locations after the incident. (Credit: Forensics Investigations Group, annotation by CSB)

At 4:10 p.m., Chesapeake noted that one Eagle employee was still missing and two of the injured personnel had been transported to Seton Austin Burn Center. At around 5:20 p.m., first responders began moving toward the well to search for the missing Eagle employee. Just before 6:00 p.m., the missing Eagle employee was found deceased near the well. At around 7:00 p.m., Chesapeake reported dry gas exiting the well, slight flow of oil exiting the casing valves, and no fluids leaving the area of the wellhead. Local fire departments reported the fire was controlled at 8:00 p.m., and Chesapeake reported seeing no fire coming from the well, with very little flow from the well, at 9:07 p.m. Personnel noted intermittent fires in and around the well until the morning of January 30, 2020. Contracted response personnel from Halliburton Boots & Coots<sup>a</sup> conducted clean-up efforts for the remainder of the day to prepare for well control operations. At 2:30 p.m. on January 31, 2020, the contracted response crew reported the well was successfully shut in.

<sup>a</sup> Halliburton Boots & Coots provides, among other services, blowout response management services.

## 2.5 INCIDENT CONSEQUENCES

As a result of the incident, three workers were fatally injured and one worker was seriously injured. One worker from Eagle was fatally injured at the well site. Three other workers, two from Eagle and one from Forbes, suffered serious burn injuries, and two of these workers, one from each company, later succumbed to their injuries. In addition to causing these fatalities and serious injuries, the blowout resulted in an estimated property damage greater than \$1 million.<sup>a</sup> On April 5, 2021, Chesapeake plugged and abandoned the well.

---

<sup>a</sup> This estimate was obtained using the Chesapeake-provided estimate of its own property damage (\$249,000) and an estimate of the cost of an equivalent model workover rig (\$780,000). Further, the estimate does not include the damages to Eagle or A&L equipment.



### 3 TECHNICAL ANALYSIS

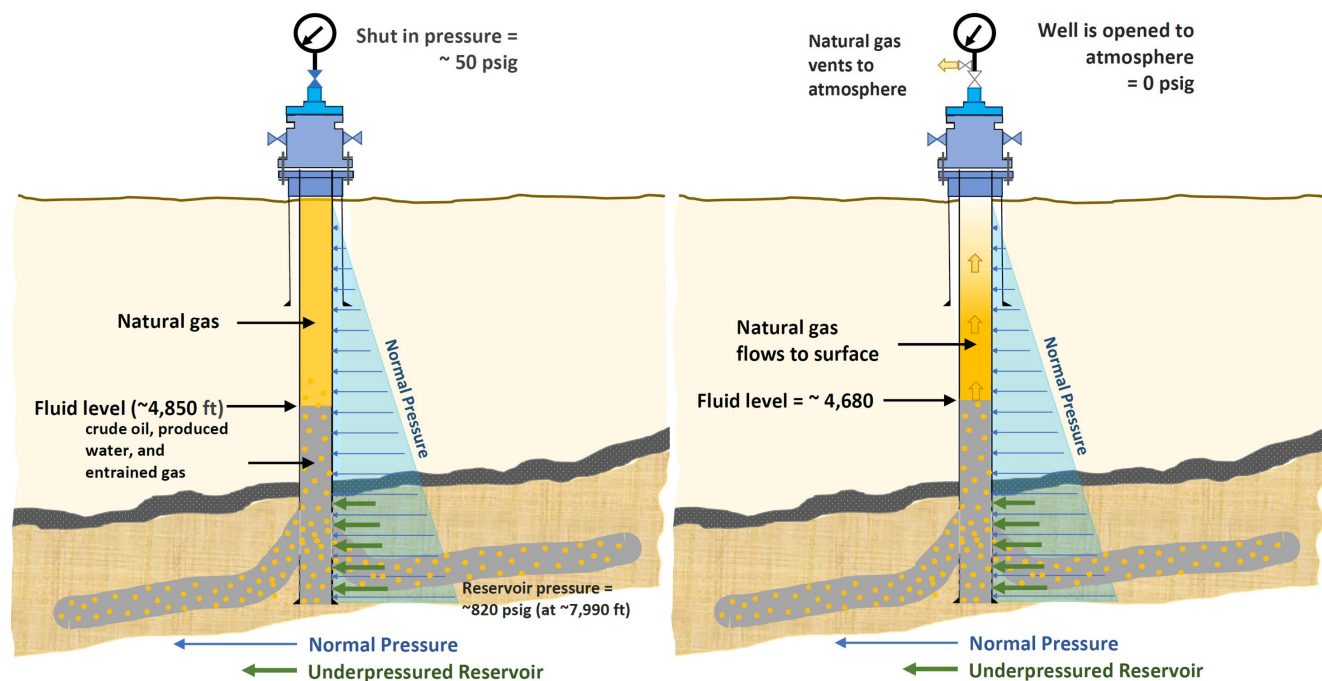
#### 3.1 WELLBORE CONDITIONS ON THE DAY OF THE INCIDENT

A narrative and physical description of the reservoir and wellbore conditions that led to the Wendland 1-H blowout are provided below.

##### *Initial Conditions*

A workover rig had been at the Wendland 1-H well location since Monday, January 27, 2020. Each morning, the crew recorded the shut-in pressure. On Wednesday morning, January 29, 2020, the day of the incident, the shut-in pressure read 50 psig (**Figure 19**, left). The wellbore fluid level was approximately 4,850 feet below the ground level based on a recent survey. The pressure measured at the surface indicated that gas had evolved from the wellbore fluid column and the well was not dead [13].<sup>a</sup> When the crew arrived at the well, they opened up the well, and bled off the pressure, but gas continued to evolve, rise up the wellbore, and exit the well from surface valves open to the atmosphere (**Figure 19**, right).

Wendland 1H – Morning of Wednesday, January 29, 2020

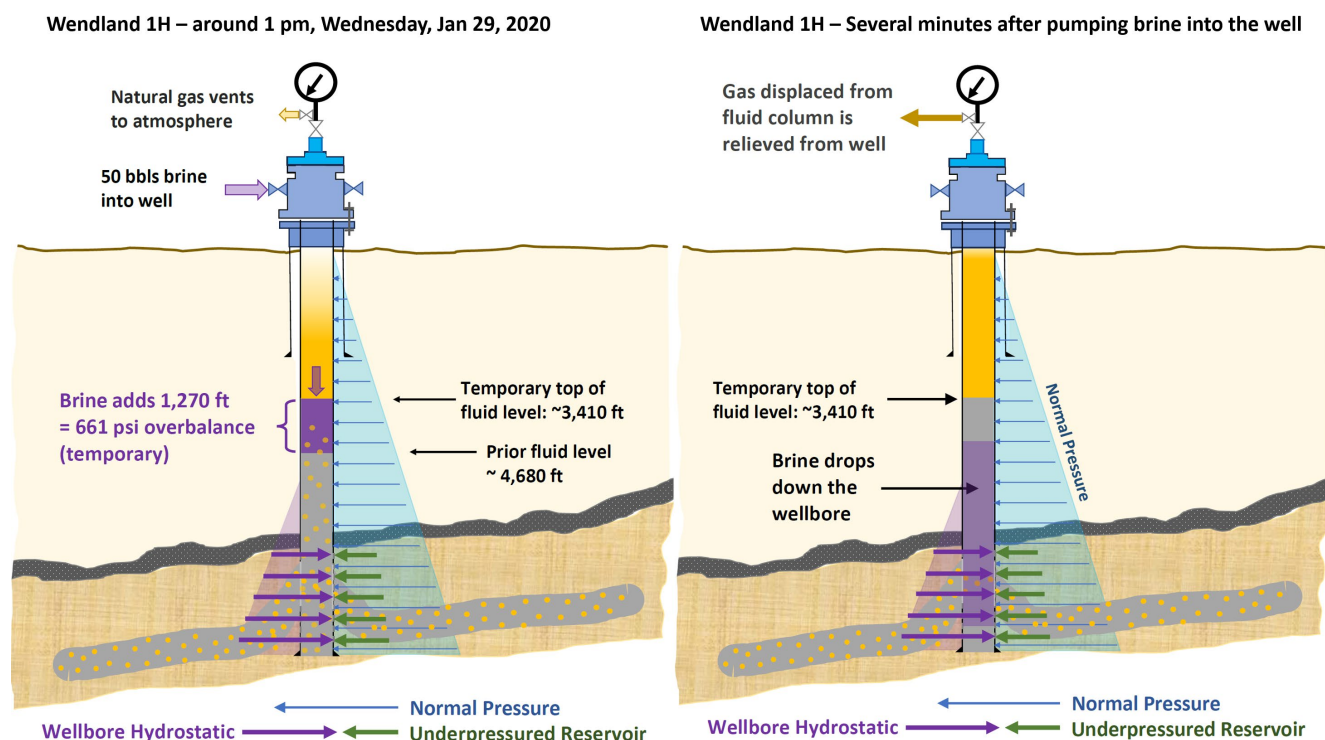


<sup>a</sup> A well is considered to be “dead” if the shut-in pressure reads zero, which indicates the well is essentially balanced. In this condition, the well can normally be opened safely to the atmosphere.

**Figure 19.** Graphical depiction of Wendland 1-H wellbore conditions the morning of January 29, 2020.<sup>a</sup> (Credit: CSB)

### *Attempt to Establish Well Control*

As shown in **Figure 20** (left), at approximately 1:00 p.m. on Wednesday, January 29, 2020, work began on the tubing head replacement. To prepare for this work, the Onsite Supervisor had A&L pump 50 bbls of 10-ppg brine into the wellbore. The volume and weight of the brine fluid was chosen based on the Onsite Supervisor's understanding of Chesapeake's practice resulting from a previous conversation with a Chesapeake employee. The intent of pumping this brine fluid was to establish a hydrostatic barrier for well control (see Section 1.5.4). No mechanical barrier was installed in the well.



**Figure 20.** Graphical depiction of Wendland 1-H wellbore conditions after pumping brine. (Credit: CSB)

**Figure 20** depicts the pumping of the brine, the temporary level increase in the wellbore, and the subsequent falling of the brine through the other wellbore fluids to the lower parts of the wellbore. The 50 bbls of brine temporarily added 1,270 feet, resulting in an overbalance against the formation face of 660 psi (calculations are contained in **Appendix B**), providing sufficient hydrostatic pressure to prevent formation fluids from entering the wellbore.<sup>b</sup>

<sup>a</sup> The figures in this section do not necessarily reflect the actual surface equipment configurations on the day of the incident.

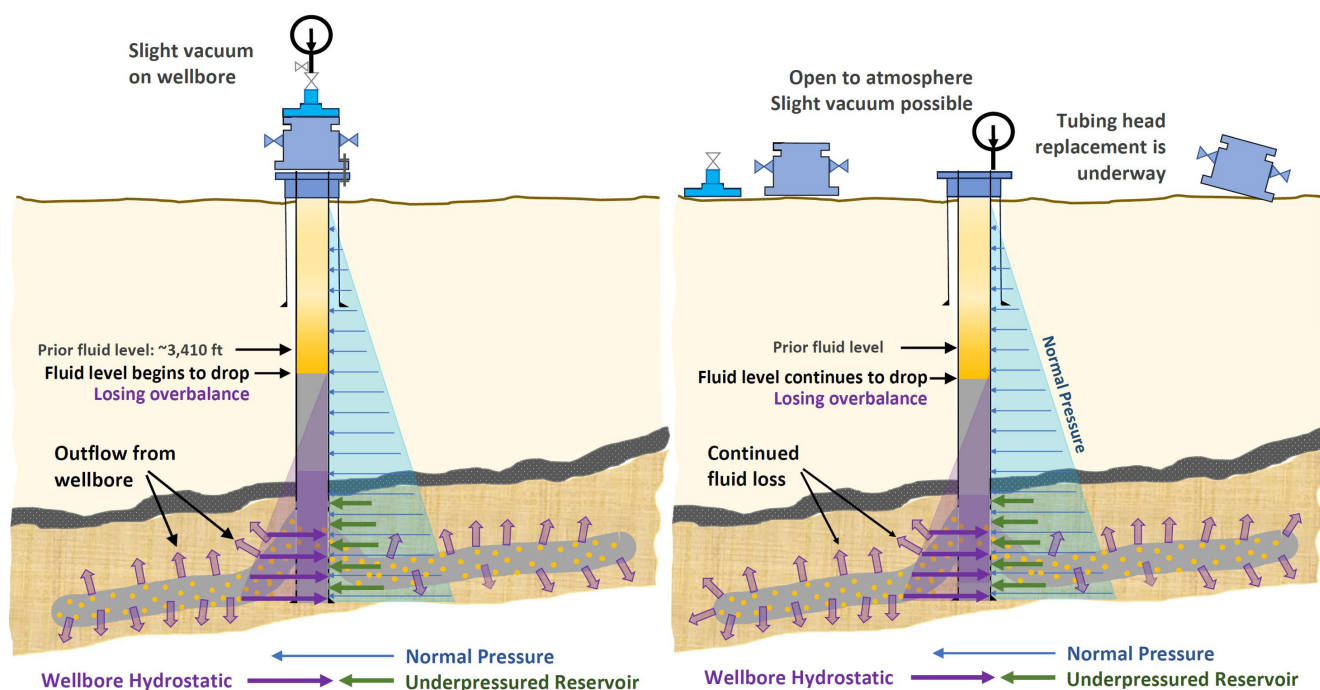
<sup>b</sup> See **Appendix B**.

### Off-Gassing and Outflow of Fluids

While the brine was dropping through the wellbore fluids, the entrained gas in the fluid column was displaced up the wellbore and vented to the atmosphere. This venting of gas, or “off-gassing,” was noted by the Onsite Supervisor and members of the different work crews.

The overbalance in the wellbore due to the added brine resulted in outflow of fluids from the wellbore into the formation (see **Figure 21**) [14, p. 207] [18, p. 231]. The rate of fluid loss into the reservoir is influenced by several factors, including pressure differential, fluid viscosity, and *completion interval* length [14, pp. 208-209]. The well's long completion interval and underpressured reservoir exacerbated the loss of fluid to the reservoir. The U.S. Chemical Safety and Hazard Investigation Board (CSB) calculated<sup>a</sup> that the rate of fluid loss to the reservoir was between 15 and 40 bbl/hour. At that rate, the 50 bbls of brine fluid would have been lost to the reservoir within 1.3 to 3.5 hours, resulting in the loss of the hydrostatic barrier.

Wendland 1H – Between 1 pm and 3 pm on Wednesday, Jan 29, 2020



**Figure 21.** Graphical depiction of wellbore conditions within two hours of blowout. (Credit: CSB)

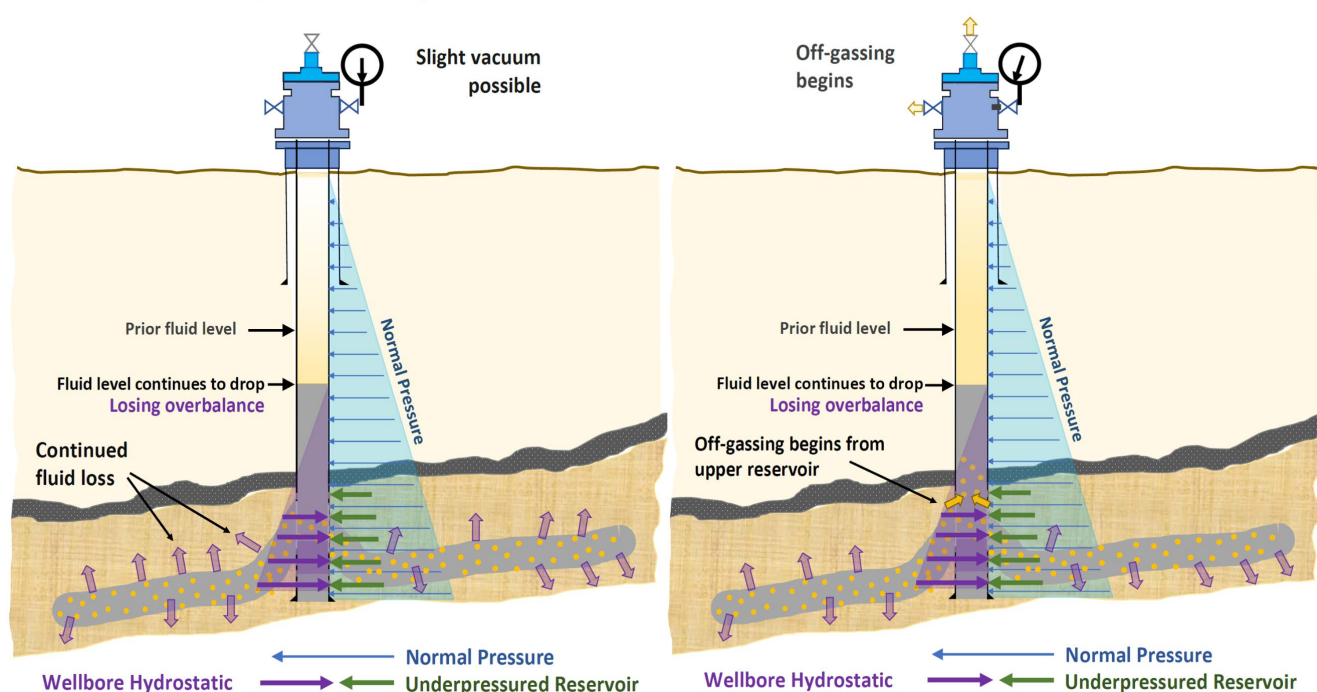
While fluids drained out of the well into the reservoir, the wellbore experienced a vacuum (see **Figure 21**) caused by the falling fluid level. The addition of fluid into the wellbore also resulted in some of the gas in the wellbore being displaced and rising to the surface, where it vented for about a minute. The vacuum and subsequent venting of gas, according to the Onsite Supervisor, were expected conditions following the addition of fluid into the wellbore. Immediately after the pumping of brine fluid, the wellbore was temporarily overbalanced, resulting in a time-limited hydrostatic barrier. At this point, after seeing a vacuum and gas

<sup>a</sup> Refer to **Appendix B** for CSB calculation.

venting, the Onsite Supervisor and other personnel believed that the wellbore was “static” or “dead” and that it was safe to do work on the well (**Figure 21**, right).

Fluid losses to the reservoir and the associated loss of fluid level continued in the Wendland 1-H wellbore as shown in **Figure 22** [18, p. 231]. As fluid level was lost in the wellbore, fluid overbalance against the formation was lost as well. As the fluid level dropped, the top of the completion interval became underbalanced first. When the top of the zone became underbalanced, gas began to flow into the wellbore. This gas inflow from the top of the completion interval occurred while fluid drained from the wellbore into the lower part of the completion interval [18, p. 231] [14, p. 207]. This wellbore dynamic is shown in **Figure 22**. Gas entered the wellbore, began flowing to the surface, and since the wellbore remained open, gas vented at the surface (**Figure 22**, right).

Wendland 1H – Before 3 pm on Wednesday, Jan 29, 2020

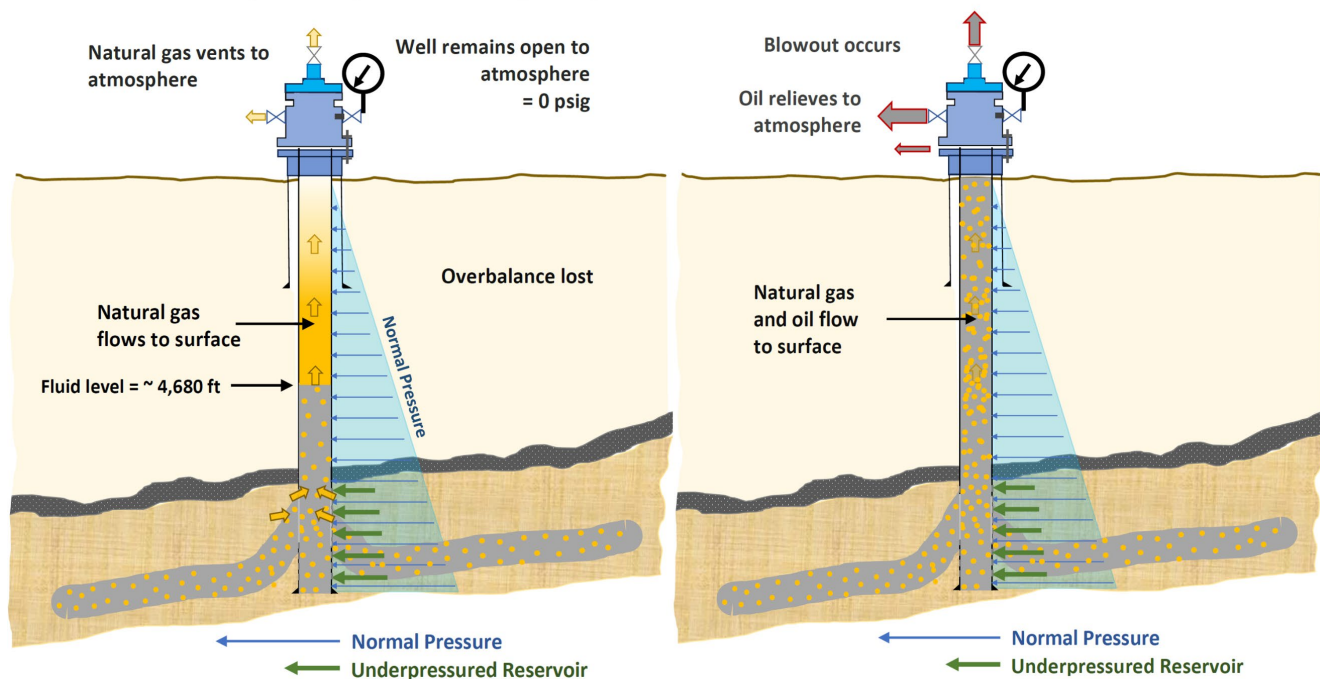


**Figure 22.** Graphical depiction of wellbore conditions before 3:00 p.m. (Credit: CSB)

### Well Blowout

Before the Wendland 1-H oil blowout to the surface occurred, workers at the location reported seeing gas venting from the well. Workers from Eagle were in the process of bolting up the wellhead when the release suddenly transitioned to a large volume of oil and gas. **Figure 23** depicts the final stage leading to the blowout and the oil and gas blowout event.

Wendland 1H – Near or just after 3 pm on Wednesday, Jan 29, 2020



**Figure 23.** Graphical depiction of wellbore conditions leading up to the blowout. (Credit: CSB)

### *Change in the Reservoir Conditions*

When Chesapeake’s contractors began the workover on Monday, January 27, 2020, the well’s shut-in pressure was 80 psig. At the start of work on Tuesday, January 28, 2020, the shut-in pressure was also 80 psig. On the morning of Wednesday, January 29, 2020, the shut-in pressure was 50 psig. After the incident, the shut-in pressure increased to around 400 psig, indicating a change from the reservoir conditions observed before the workover began. The fact that the well was previously on artificial lift and then flowed oil to the surface during the blowout also indicates a change had occurred in the reservoir conditions [12].

Potential reasons for changes in the reservoir that could have led to the well fluids flowing to the surface and increasing the shut-in pressure post-event include the following:

1. Communication with other nearby wells<sup>a</sup> undergoing high-pressure injection or hydraulic fracturing (called “fracking”). Communication with nearby “fracked” wells is called frac interference or “frac hits.”
2. Destabilizing the reservoir at or near the formation face (i.e., inadvertent stimulation) during reverse flow into the reservoir.

<sup>a</sup> Communication between two wells occurs when a flow path exists between the two wellbores.

3. Varying permeabilities and porosities within a reservoir can result in areas of higher pressure that were not previously accessed [19].
4. The lightening of the wellbore oil column by the gas percolating through the fluid column, which could have also contributed to the release of oil to the surface [20].

The increase in shut-in pressure following the incident indicated that a change in reservoir conditions occurred. Based on the lack of the ability to continuously monitor reservoir conditions and the lack of available information on offset fracking operations, the CSB was unable to determine which of the above reasons for the change, or which combination of reasons, caused the increase in reservoir pressures.

The CSB concludes that the well blowout occurred as a result of both a loss of fluid overbalance and a change in the reservoir conditions, allowing oil and gas to flow to the surface.

## 4 SAFETY ISSUES

The following sections discuss the safety issues contributing to the incident, which include:

- Well Planning
- Well Control for Completed Wells in Underpressured Reservoirs
- Ignition Source Management
- Federal Regulatory Safety Requirements

A graphical causal analysis is included in **Appendix A**.

### 4.1 WELL PLANNING

The Well Planning section of the American Petroleum Institute's (API) Recommended Practice (RP) 59, *Recommended Practice for Well Control Operations*, which is intended to prevent the release of hydrocarbons from a well, advises to first gather well information, then to analyze the data and formulate a list of potentially hazardous events, and finally to determine safeguards against hazardous events. API RP 59 also states that "operating procedures should be prepared and posted." Although much of this section of API RP 59 is intended to be implemented prior to drilling, it is also applicable to workover operations [16, p. 38].

#### *Well History Review*

Chesapeake did not include in its policies a stipulation to conduct a well history review, and neither Chesapeake nor its contractors reviewed the workover history to evaluate previous well control operations. A planning review per API RP 59 would have included, among other things, a review of well control indications and any well control problems. The CSB conducted a review of the Wendland 1-H well's workovers, and details of the CSB's review are contained in **Appendix C**. The CSB's review of that history identified at least 22 prior well control events<sup>a</sup> and records of "off-gassing" at the Wendland 1-H well during 34 workovers since 1993.

Had this information been reviewed at some point prior to the incident, Chesapeake and its contractors may have recognized that the historical approach of pumping a batch volume of fluid into the well was ineffective. A complete workover history review also would have revealed that the Wendland 1-H well, in some instances, was capable of flowing, as shown in **Appendix C**.

The CSB concludes that a review of the well history, as recommended by API RP 59, would have revealed past instances where the Wendland 1-H well could flow oil during a workover. Such recognition may have led to heightened awareness of the potential for well control problems and earlier action taken to maintain well control.

---

<sup>a</sup> For the purposes of this report, a "well control event" is defined as an unplanned release of hydrocarbons from the well.

The CSB recommends that Chesapeake develop or revise policies incorporating the recommendations of API RP 59 regarding well planning, specifically the inclusion of well history review in conjunction with workover well control planning.

### *Operating Procedure*

A well planning review conducted per API RP 59 could have resulted in the preparation and posting of well control procedures applicable to the workover well conditions. A step-by-step workover procedure was prepared by Chesapeake and provided to the Onsite Supervisor for the original job scope to repair a suspected tubing leak on the Wendland 1-H well. However, this procedure did not include instructions on how to establish and maintain well control. Also, Chesapeake did not provide written well control procedures for the tubing head replacement task. Instead, Chesapeake, after verbally instructing the Onsite Supervisor to use 50 bbls of 10-ppg brine, entrusted the Onsite Supervisor to determine the necessary additional well control steps to be performed.

The absence of well planning per API RP 59, which stipulated the need for well control procedures, allowed the work to progress without having a written procedure for establishing and maintaining well control. Well planning could have further triggered the need for written contingency procedures in the event the well did flow.

The CSB concludes that Chesapeake did not provide written operating or contingency procedures for establishing and maintaining well control. Had Chesapeake and its contractors performed well planning in accordance with API RP 59, an operating procedure describing the instructions for establishing and maintaining well control would have been prepared and posted for use by contractors performing the workover operations.

Following the incident, Chesapeake implemented well control procedure templates for several standard workover procedures, including casing valve replacements and addressing holes in tubing. These templates can be used in future workovers to develop site-specific workover well control procedures, provided the procedures are based on the respective well history.

## **KEY LESSON**

To successfully execute well control, proper well planning is required. Industry guidance recommends gathering well information, evaluating potential hazards based on that information, and creating operating procedures and contingency plans to address those hazards. Companies should incorporate well planning, based on industry guidance, into their well control policies and procedures.

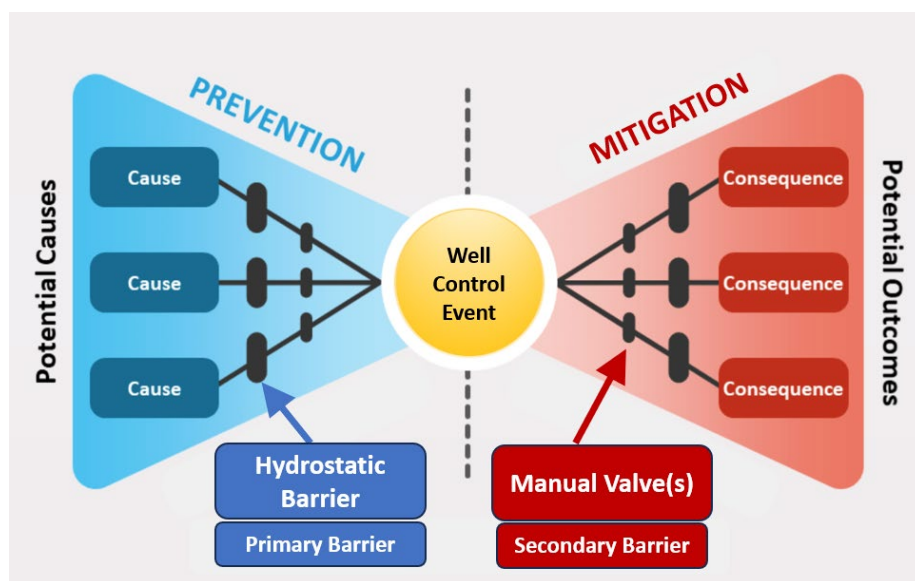
## **4.2 WELL CONTROL FOR COMPLETED WELLS IN UNDERPRESSURED RESERVOIRS**

A well is considered “completed” once the well is constructed and is ready to begin producing hydrocarbons [21]. After a well is completed and producing, workover operations, such as the workover being performed on the Wendland 1-H well at the time of the incident, are performed as necessary to repair or service the well. In



API RP 59, *Recommended Practice for Well Control Operations*, the API provides well control procedures “intended to safely prevent or handle kicks<sup>a</sup> and re-establish primary well control” [16, p. 6].

Methods that stop fluids from reaching the surface and exiting the well are preventive. Well control can also refer to methods that maintain control of the well in the event of a flow event or kick. These methods are mitigative. A typical method for preventive well control is using a hydrostatic barrier, also referred to as the primary well control barrier. Mitigative controls applied after flow has reached the surface are also referred to as secondary barriers. Closure of blowout preventers (BOPs) and valves at the surface are commonly used as secondary barriers for well control barriers. The BowTie diagram below shows the relationship of well control barriers to a blowout event (**Figure 24**).



**Figure 24.** BowTie diagram relating well control barriers to a blowout event. (Credit: Presentationgo.com, adapted by CSB [22])

### *Challenges to Achieving Well Control in Completed Wells*

As API RP 59 explains, primary well control is normally accomplished by maintaining “hydrostatic pressure in the wellbore that is equal to or greater than the formation pressure,” [16, p. 7] thereby preventing flow from the formation into the wellbore, known as an influx [16, p. 4]. The Wendland 1-H well presented several challenges regarding primary well control using a hydrostatic barrier:

#### *Open path to the reservoir*

First, during a workover, completed wells have an open path through the completion interval to the reservoir [17, p. 69] [23, pp. 22-3].

#### *Clear fluids*

<sup>a</sup> The API describes a “kick” as “formation flow during...well servicing operations [16, p. 6].”

Second, to prevent *formation damage*, a hydrostatic barrier in completed wells typically uses clear,<sup>a</sup> solids-free fluids. The use of clear, solids-free fluids, like the brine used as a workover fluid in this instance, increases the risk of fluid losses to the formation compared with typical drilling fluids [14, p. 2].

### *Underpressured reservoir*

Third, this reservoir was underpressured. Fluid added to the wellbore initially provides overbalance against the formation. However, in underpressured reservoirs, the fluid added will flow into the reservoir until overbalance is lost. When overbalance is lost, an influx, or kick, can enter the wellbore [18, p. 231] [23, pp. 22-3]. Several texts highlight the potential for simultaneous fluid losses to one zone while gas or liquids may be entering the wellbore from another higher zone in the same reservoir [23, pp. 4, 10] [17, p. 70] [14, p. 207].

### *High gas-to-oil ratio*

Fourth, the Wendland 1-H well produced oil and gas at a gas-oil ratio ranging between 3,000 and 8,300 standard cubic feet per barrel. In the months leading up to the incident when the well was not producing any oil, the well continued to produce gas, as much as 77,000 cubic feet per day. The lighter natural gas will rise through the workover fluids toward the surface and off-gas if a barrier does not prevent that flow [23, p. 2].

Because of these challenges, well control methods in completed wells—especially in underpressured reservoirs—require special considerations [23, pp. 1, 6] [14, p. 2]. The following are some specific examples of methods that can be used to accomplish effective well control in completed wells in underpressured reservoirs:

- 1) **Continuous fluid addition.** If clear fluids are used such as fresh water or brine without additives, the fluid must be continually added [23, pp. 2, 5] [18, p. 231] [14, p. 208]. Where feasible, continuous fluid addition can maintain an overbalanced condition in a wellbore, provided that the rate at which it is added exceeds the rate at which it flows from the wellbore into the reservoir.
- 2) **Viscous fluids.** Viscous fluids can be used to prevent the loss of the hydrostatic barrier by placing a batch of thick, high viscosity fluid into the wellbore known as a fluid loss control pill [14, p. 208]. Polymers such as hydroxyethyl cellulose (HEC) and xanthan gum (XC) can also be added to workover fluids to increase the viscosity [18, pp. 231-232]. High viscosity fluids will decrease the fluid flow rate from the wellbore into the formation, allowing an overbalanced condition to exist for a longer duration.
- 3) **Bridging solids.** Mixing bridging solids into the workover fluid can also prevent fluid losses to the formation. Bridging agents mechanically block the leak paths. Non-damaging bridging solids are described by Crumpton and others [14, pp. 210-212] [18, pp. 232, 243]. Blocking leak paths from the wellbore into the reservoir would prevent fluid losses and maintain a hydrostatic barrier for a longer duration.
- 4) **Mechanical barriers.** Setting a mechanical barrier can address fluid losses in situations where the wellbore configuration allows for setting a plug [14, p. 212] [16, p. 54]. The mechanical plug must be set above the top of the completed zone [18, p. 234].

---

<sup>a</sup> Some workover fluids are commonly referred to as “clear” fluids, as they contain no suspended solids [42].

## 4.2.1 INEFFECTIVE HYDROSTATIC BARRIER

Chesapeake's Barrier Policy outlined the "minimum expectations for both the number and selection of [well control] barriers" for all well operations, including workovers. This policy defined a "barrier" as "a component or practice that contributes to the total system reliability by preventing liquid or gas flow, when properly executed." As discussed in Section 2.2, prior to removing the existing tubing head, the Onsite Supervisor, based on the perception of Chesapeake's usual practice, attempted a hydrostatic barrier using 50 bbls of 10-ppg brine.

As shown in **Figure 24**, establishing and maintaining of an effective hydrostatic barrier is necessary to prevent formation fluids from entering the wellbore, which could result in a loss of well control. Chesapeake directed the use of brine, a clear fluid, in an attempt to establish and maintain a hydrostatic barrier. Given the use of a clear fluid in an underpressured reservoir, it would have been necessary to continuously add the fluid exceeding the rate of fluid loss in order to achieve an overbalance for the duration of the task of replacing the tubing head. The Onsite Supervisor did not do this, however.

Chesapeake also could have instructed the Onsite Supervisor to use a high viscosity fluid instead of brine as a workover fluid. As demonstrated in calculations in **Appendix B**, a higher viscosity fluid would have resulted in a slower fluid loss rate into the reservoir, resulting in a greater duration of overbalance in the wellbore. Because of the longer duration of overbalance, this method would have been a more effective hydrostatic barrier option than using brine.

At the time of the incident, Chesapeake's Barrier Policy did not contain provisions for using continuous fluid addition or high viscosity workover fluids as hydrostatic barriers. Inclusion of these methods into Chesapeake's policy may have resulted in the use of one of these methods instead of simply using a batch volume of brine.

The CSB concludes that Chesapeake failed to provide effective well control guidance, and Chesapeake's contractors failed to maintain an effective hydrostatic barrier because Chesapeake's Barrier Policy did not incorporate appropriate methods for maintaining a hydrostatic barrier for a completed well in an underpressured reservoir.

Following the incident, Chesapeake superseded its Barrier Policy with a Barrier Standard that includes the requirement to maintain fluid levels and conditions. Chesapeake also implemented Barrier Exception Procedures that apply to specific circumstances during workovers, which include the use of continuous fluid addition to establish and maintain a hydrostatic barrier.

## 4.2.2 INEFFECTIVE SECONDARY BARRIER

According to the International Association of Drilling Contractors (IADC), a "secondary well barrier" is defined as a "second set of well barrier elements that prevent flow from..." an influx of formation fluids [24]. In addition to the attempted hydrostatic barrier discussed in Section 4.2.1, Chesapeake and its contractors used an open stabbing valve and the open casing valves as secondary well control barriers. As shown in **Figure 24**, a secondary barrier is a mitigative control that provides protection against an incident to prevent a blowout after well control has been lost.

Chesapeake's Workover and Completions BOP Manual (BOP Manual) addresses Chesapeake's minimum requirements for blowout prevention equipment used in workover operations. One of the BOP Manual's stated objectives is to prevent unplanned releases. The manual discusses stabbing valves,<sup>a</sup> also called a full-opening safety valve (FOSV). **Figure 25** shows an exemplar FOSV and the FOSV in use at the time of the incident. The Barrier Policy listed an FOSV as an example of a mechanical barrier, and the BOP Manual lists the requirements for using an FOSV. Among those requirements are that an FOSV with its operating wrench must be available and on the *rig floor* at all times. The BOP Manual also notes that the FOSV is "only to be used as an emergency valve during well control operations."



**Figure 25.** Cutaway view of exemplar FOSV (left) (Credit M&M International [25]) and the FOSV used at the time of the incident (right). (Credit: CSB).

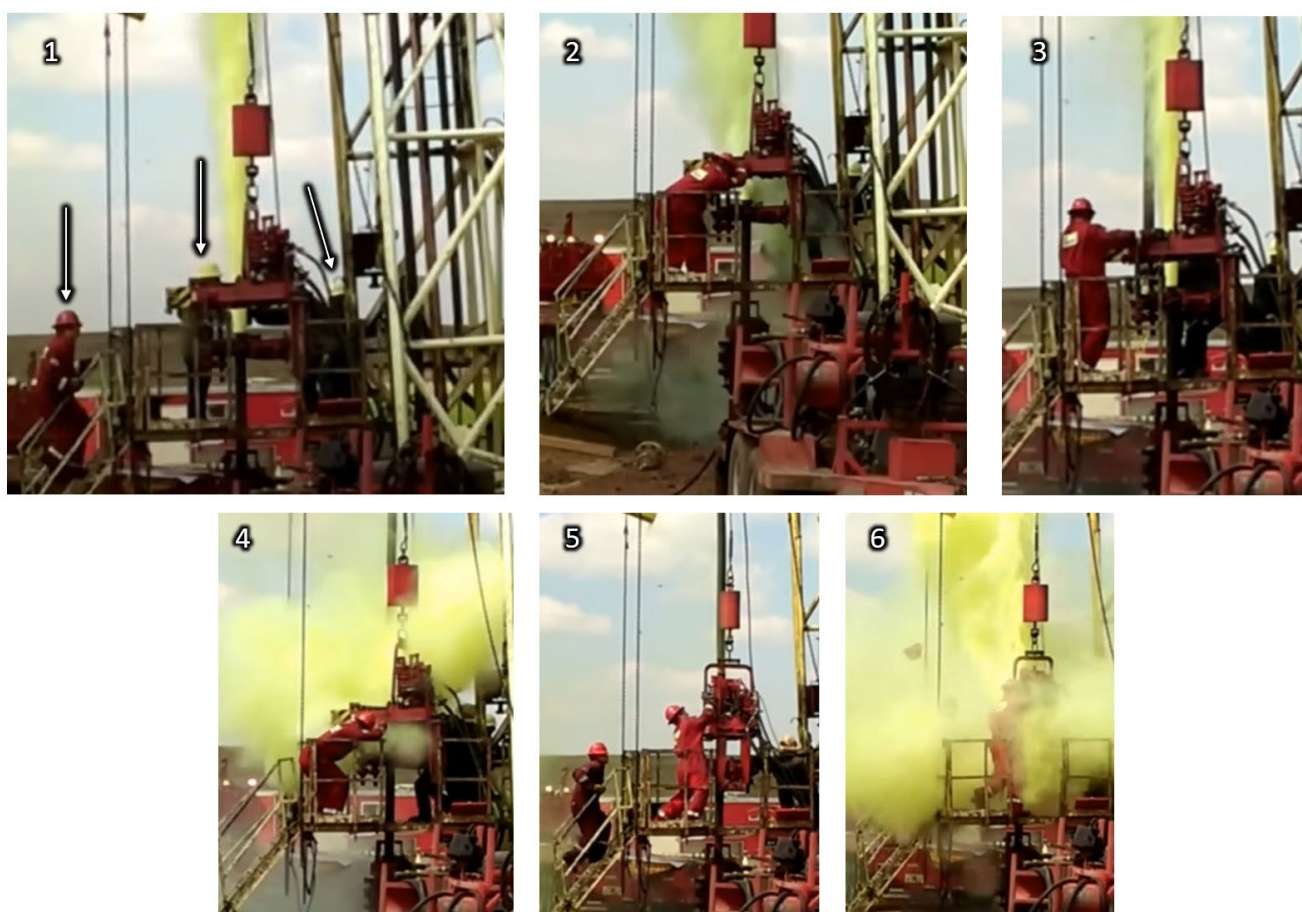
During this incident, the FOSV was installed and open versus "on the rig floor," and Chesapeake told the CSB that it considered an open FOSV to be a barrier per its policies. With the tubing head and casing valves disconnected from pressure-measuring equipment, however, there was no way to monitor for changes within the wellbore indicating the occurrence of a kick. Therefore, the open FOSV and casing valves would have only been closed upon (1) human detection of an influx and (2) human action to close the valves. As illustrated in **Figure 24**, any open surface valve requiring closure for barrier implementation constitutes a mitigative barrier, making it less reliable. Also, since the new tubing head was not yet fully bolted into place, it did not meet the criteria to be considered a barrier.

<sup>a</sup> The IADC identifies "stabbing valve" as a safety valve and defines it as "a full opening valve available for quick installation..." [43].

In addition to being a less reliable mitigative barrier, the human action of closing a stabbing valve in response to a blowout would place a worker in the immediate vicinity of a flammable atmosphere with a potentially spark-producing hand tool, increasing the risk of a flash fire. The Onsite Supervisor described the operation of a stabbing valve to the CSB:

But [the] first move is [to] always...always get the [stabbing] valve in there. That's the very first move. You may put...it on there...in an open position, never closed. If it's closed and it starts blowing water and gas, ...it's harder to screw down when it's under pressure. So if it's blowing, you get it screwed on there. Then you shut the valve...then everything's safe.

To further illustrate the hazards associated with the use of stabbing valves, **Figure 26** and **Figure 27** show two examples of workers using or attempting to use stabbing valves to shut in wells.



**Figure 26.** Attempt to install a stabbing valve, with the sequence described as follows: (1) As the blowout progresses, three workers (indicated with arrows) approach the release point, (2) the first attempt to line up the pipe to which the stabbing valve is attached, (3) pressure pushes the pipe away from well, (4) the second attempt to line up the pipe, (5) workers successfully line up the pipe and attempt to thread it onto the well, (6) pressure again pushes the pipe away from the well. (Credit: YouTube [26], annotations by CSB)



**Figure 27.** Two workers closing a stabbing valve following a blowout. (Credit: YouTube [27], annotation by CSB)

The CSB concludes that the use of open surface valves and stabbing valves as a well control barrier is not effective since it (1) is a mitigative control actuated after the release begins and (2) increases the risks to workers in the event of a release by creating a flammable vapor cloud around them with potential ignition sources nearby.

### 4.2.3 INDUSTRY GUIDANCE

API RP 59, *Recommended Practice for Well Control Operations*, provides guidance on well control operations and is intended to be used both as a well control field aid and as a technical source for well control instruction. API RP 59 establishes recommended practices for preventing a loss of well control and, if a loss of well control occurs, recommended practices to re-establish well control [16, p. 1].

#### *Establishing a Primary Barrier*

Section 5 of API RP 59 states that one of the conditions necessary for a kick is insufficient hydrostatic pressure [16, p. 32]. API RP 59 further states that failure to maintain a full column of fluid, among other conditions, can result in the loss of well control [16, p. 32]. For wells in underpressured reservoirs like the Wendland 1-H well, API RP 59 Section 5.2.3.2 states that “consideration should be given to keeping a volume of fluid in reserve to add...into the well as needed to maintain control” [16, p. 32]. This is the only instance in API RP 59 that addresses well control for completed wells in underpressured reservoirs.

In an underpressured well such as the Wendland 1-H well, the use of water, brine, or other clear fluids makes it difficult, if not impossible, to monitor from the surface since these fluids would be lost to the formation [14, p. 236]. Therefore, the guidance provided by API is not conducive to establishing an effective hydrostatic barrier since any reserve fluid added to a well would simply be lost to the formation and cannot be monitored. Further, API RP 59 does not discuss special considerations in addressing the specific challenges with well control in completed wells, including in underpressured reservoirs, as discussed in Section 4.1.

The CSB concludes that the present API guidance for well control involving completed wells in underpressured reservoirs is not adequate for the implementation of an effective hydrostatic barrier. Had more robust guidance been presented in API RP 59, Chesapeake may have instituted more effective well control practices, potentially preventing the incident from occurring.

#### *Establishing a Secondary Barrier*

Like Chesapeake’s BOP Manual, API RP 59 also references the use of a safety valve when “handling pressure,” implying that the use of a stabbing valve like the FOSV used at the time of the incident may constitute a secondary well control barrier. For the reasons stated in Section 4.2.2, the CSB concludes that the use of stabbing valves, as mentioned in API RP 59, is not an effective well control barrier.

API RP 59 Section 11.11.1 states, “If a well is considered to have potential to flow, maintenance of...two barriers to [a] flow system should be considered,” including fluid overbalance, mechanical devices, and plugs [16, p. 54]. Further, Section 11.11.2 lists other practices for handling pressure, one of which is having a stabbing valve available on the rig floor [16, p. 54].

As discussed in Sections 3.1 and 4.1 of this report, it is possible for a static well to become underbalanced, resulting in a loss of well control without appropriate barriers in place, especially considering that a “genuinely static well is difficult to achieve” when using water or brine [14, p. 236]. Because of this phenomenon, a well should always be considered to have the potential to flow. API’s recommendation to consider two barriers *only if a well can flow* provides a false sense of security to companies that operate underpressured wells, enabling the practice of operating with only one barrier in place.

Further, the CSB’s review of the Wendland 1-H well’s workover history (discussed in Section 4.1) found that a common practice for workover well control was to initially pump a fixed volume of workover fluid as a hydrostatic barrier. In some instances, no well control barriers were in place, and pumping water into the well was a reactive attempt to keep gas levels suppressed. This indicates a tendency for workers to be willing to accept the risk of some amount of gas coming out of the well during workover operations.

The Onsite Supervisor acknowledged that oil and gas coming out of a well is not unusual:

...if you’re working on live wells, you’re going to have kicks...that’s just [an] ordinary occurrence with things. The well’s going to kick. You can see my shirt. That’s what happens when you get a kick up the tubing and you’re pulling rods. It blows oil all over...and...you secure the well. ...If it’s just a normal gas or oil kick, then...you need to get it shut in [as] quickly as possible.

The Onsite Supervisor stated further:

So...having some...vapors at the surface is...not a real great concern. I mean...it’s a common thing. I mean...there’s a difference between having vapors and a well...blowing or gassing.

One worker noticed gas coming out of the well before they removed the existing tubing head and notified the Onsite Supervisor. After the Onsite Supervisor indicated that they would be safe, the worker expressed no concern about a potential blowout and continued activities. These actions—the Onsite Supervisor indicating that they were fine and the worker continuing activities after seeing gas venting from the well—indicate that working around a well in the presence of gas was a normal condition at the Wendland 1-H well.

Based on the CSB’s review of the Wendland 1-H well’s workover history under multiple operators, the CSB concludes that working in the presence of gas during workover operations was a common practice. The CSB further concludes that this practice may have been normalized as a result of API RP 59 language that allows operators to consider flow potential rather than stipulate the recommendation for a two-barrier-to-flow system,

## KEY LESSON

Despite having substantial industry guidance regarding how companies should conduct well control, industry guidance is lacking regarding specific well control methods for completed wells in underpressured reservoirs. Companies that operate these types of wells need to be aware of this gap and use necessary resources, such as other recognized technical literature, such as *Well Control for Completions and Interventions* by H. Crumpton, when creating well control policies and procedures for workovers.



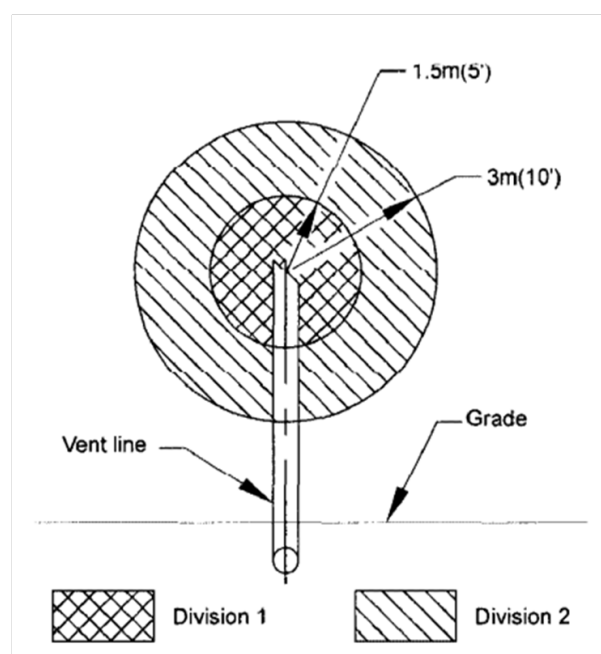
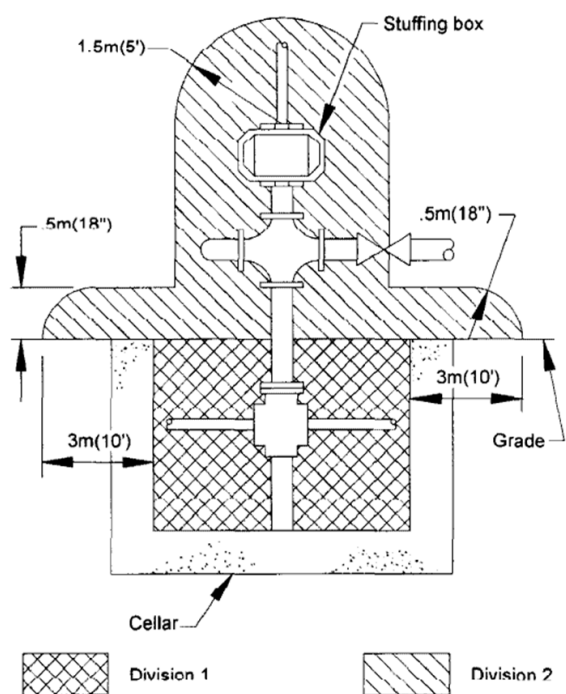
and that API RP 59's language regarding the consideration of a two-barriers-to-flow system does not provide adequate guidance to companies operating underpressured wells.

The CSB recommends that API publish the following information in an appropriate document such as API RP 59 *Recommended Practice for Well Control Operations*:

1. A focused discussion on practices applicable to workover operations, including completed wells in underpressured reservoirs. Include well control methods applicable to workover operations, such as using continuous fluid addition, viscous fluids, bridging solids, and mechanical plugs. Also include a discussion on the well control challenges and hazards specific to workover operations;
2. Stabbing valves should not be considered as well control barriers for workover operations; and
3. Every well should be considered to have potential to flow, and therefore, should have two well control barriers, one of which should be a preventative barrier.

## 4.3 IGNITION SOURCE MANAGEMENT

API RP 500, *Recommended Practice for Classification of Locations for Electrical Installations at Petroleum Facilities Classified as Class I, Division 1 and Division 2*, defines a hazardous or classified location as a location where fire or explosion hazards may occur due to flammable gases or liquids. The API provides examples of classified areas at petroleum facilities based on the equipment present in the areas. **Figure 28** provides examples of the classification diagrams for various pieces of equipment. Class 1 areas are classified based on the presence of flammable gases or vapors. The classification is further categorized by divisions. Division 1 locations are those where the concentration of flammable gases is expected under normal conditions. Division 2 locations are those where the concentration of flammable gases may be present but can be prevented from accumulating using ventilation [28].



**Figure 28:** Examples of classified areas in API RP 500 (Credit: API)

These classified areas are critical in identifying the areas in which flammable gases can be present and can be the basis for siting potential ignition sources.

### 4.3.1 POTENTIAL IGNITION SOURCES

At the time of the blowout, a mixture of flammable hydrocarbons (oil and gas) was released from the well. Due to the pressure from the blowout, the flammable hydrocarbons were released rapidly, forming a vapor cloud, which found an ignition source. Multiple potential ignition sources were identified in the vicinity of the open wellbore. These included, but are not limited to:

- Static electricity

- Workover rig
- Hot oil truck
- Eagle truck
- Diesel-powered generator on Eagle trailer
- Forklift
- Hand tools
- Electric hydraulic pump (power pack) with extension cord
- Handheld controller for the torque wrench

Figure 29 shows an overhead view of the well following the incident with a number of potential ignition sources and their respective distance from the well. Figure 29 also shows that the workover rig, the Eagle truck and trailer, the forklift, and the hot oil truck sustained fire damage.

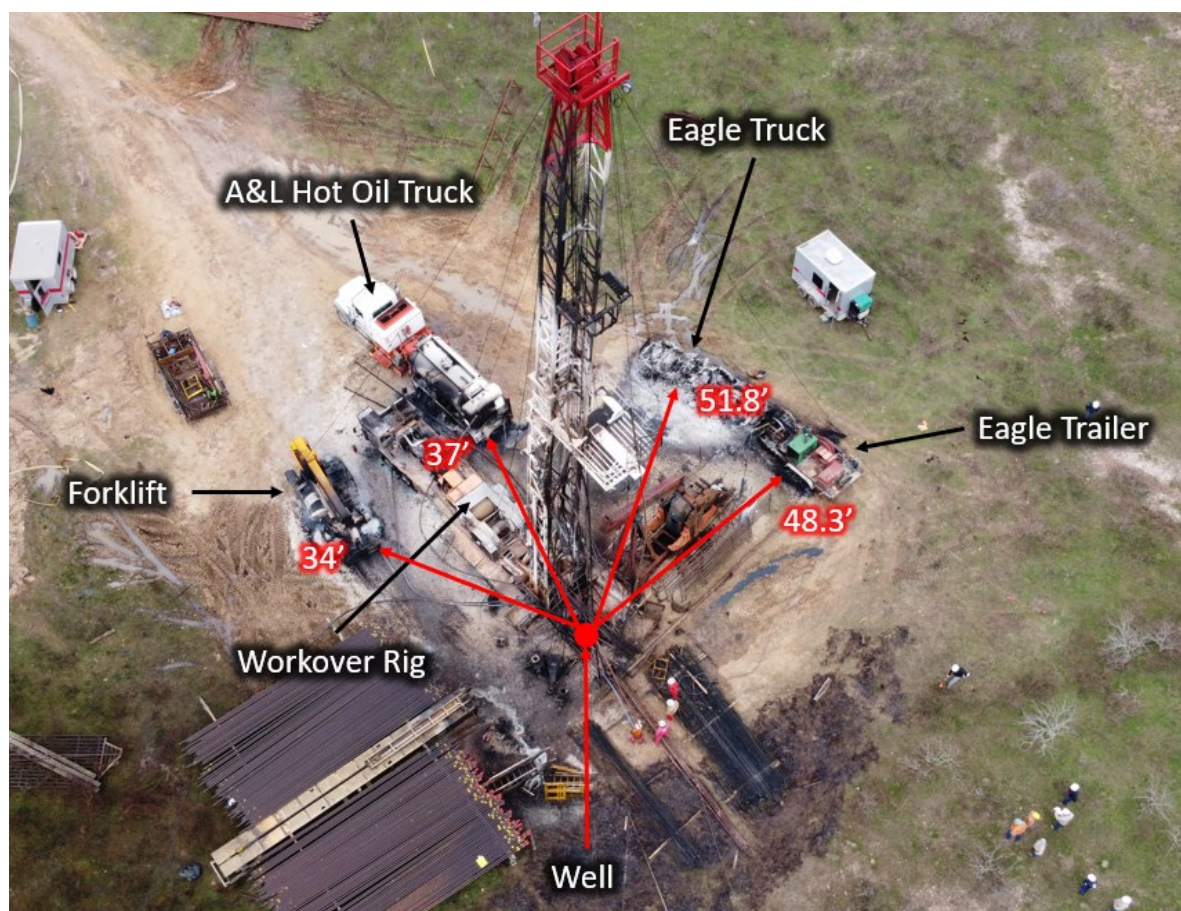


Figure 29. Overhead view of the Wendland 1-H well with distances to various potential ignition sources.<sup>a</sup>  
(Credit: Chesapeake, annotations by CSB)

<sup>a</sup> Distances were provided by Chesapeake.

The power pack, extension cord, and handheld remote controller were located approximately 10 feet from the wellbore (**Figure 30**), all of which appeared to have sustained fire damage.



**Figure 30.** Hydraulic power pack (circled) location following the incident. (Credit: Chesapeake, annotation by CSB)

Given the multiple release points shown in **Figure 17** and the dynamic nature of the release, the CSB was unable to identify the exact ignition source.

### 4.3.2 INSUFFICIENT RISK ASSESSMENT

Chesapeake’s Contractor Health, Safety, Environmental, and Regulatory Handbook discusses the location of ignition sources, specifically regarding hot work<sup>a</sup> and the use of lower explosive limit (LEL) monitoring. The Handbook requires a hot work permit when performing, among other things, activities that use spark producing power tools within 35 feet of any potential flammable sources. The Handbook also states that internal combustion engines require “continuous atmospheric monitoring when operating within 35 feet of any potential flammable atmosphere.” Although the Handbook discusses hand tools, it does not require that contractors use

---

<sup>a</sup> The Occupational Safety and Health Administration (OSHA) defines “hot work” as “riveting, welding, flame cutting or other fire or spark-producing operation.” 29 CFR § 1917.152

non-sparking tools. Further, the Handbook does not contain any stipulations regarding the placement of potential ignition sources within or near classified areas as defined by API RP 500.

Chesapeake's Job Safety Analysis (JSA) form, which was used by its contractors as a checklist for identifying the hazards associated with the workover on the day of the incident, includes "Ignition Sources" as a potential hazard. The JSA form does not contain any requirements regarding the placement of ignition sources, however, nor does it require ignition hazards to be assessed based on classified areas as defined by API RP 500.

API RP 54, *Occupational Safety and Health for Oil and Gas Well Drilling and Servicing Operations*, provides several guidelines for performing assessments to determine the safe location of equipment from flammable and combustible sources.

A risk assessment should be performed and communicated to the affected crew and other personnel (as appropriate) that determines the appropriate safe location and distance from the wellbore and other potential flammable and combustible sources, appropriate safety measures for hot work, welding, and flame cutting operations, and the requirement for a written procedure [29, p. 20].

Furthermore, API RP 54 recommends the following:

Area classifications determine the type of and maintenance requirements for electrical equipment on drilling and well servicing rigs under normal operating conditions. When special service operations are being performed, the recommendations for electrical installations under the conditions of service should be followed [29, p. 27].

API RP 99, *Flash Fire Risk Assessment for the Upstream Oil and Gas Industry*, provides general guidance on the identification of hazards that could result in flash fires. As part of the prevention of flash fires, the control of ignition sources is listed to reduce the risk of flash fires. API RP 99 also provides examples of the electrical hazardous area classifications, which are examples from API RP 500, for electrical equipment with several orientations of equipment.

API RP 99 further provides general guidance for risk assessments to prevent flash fires, using as an example a bow-tie analysis, which highlights the need to control the ignition source location in proximity to a fuel source to prevent flash fire hazards [30, p. 15].

According to a report prepared for Chesapeake,<sup>a</sup> the power pack used to bolt the tubing head was not intrinsically safe, but Eagle workers believed that the equipment was intrinsically safe. OSHA has specified in 29 Code of Federal Regulations (CFR) 1910.307, *Hazardous (Classified) Locations*, the requirements for electrical equipment in locations that are classified depending on the properties of flammable vapors, liquids, or gases that can be present.<sup>b</sup> OSHA requires electrical equipment to be intrinsically safe, approved for the

---

<sup>a</sup> On February 18, 2020, Chesapeake representatives requested that Forensic Investigations Group, L.L.C. conduct a fire analysis of the incident to include a determination of origin and cause of the fire. The report was completed on June 13, 2022.

<sup>b</sup> <https://www.osha.gov/laws-regs/regulations/standardnumber/1910/1910.307> (a)(1)

hazardous location, or safe for the hazardous location.<sup>a</sup> Furthermore, OSHA's regulations not only specify that any electrical equipment must be approved for use in a hazardous location based on classification and division but also outline the specific properties of the materials that can be present, defined by material groups. This classification is synonymous with the group designations that are listed in the National Fire Protection Association (NFPA) 70.<sup>b</sup>

Despite industry guidance and regulatory requirements, workers at the Wendland 1-H well site did not locate ignition sources in accordance with established safe practices. During workover operations, some ignition sources, such as an internal combustion engine of a workover rig, are unavoidable. In the book *What Went Wrong? - Case Histories of Process Plant Disasters and How They Could Have Been Avoided*, Trevor Kletz explains that despite efforts to remove ignition sources, flammable atmospheres still have a high probability of igniting [31, p. 454]. However, increasing the number of potential ignition sources also increases the chance of a flammable release finding an ignition source. Mitigation efforts against the risk of potential ignition sources should include eliminating ignition sources where possible. For example, using hand tools made from non-sparking materials (i.e., brass or aluminum) instead of ferrous metals would eliminate the possibility of generating a spark resulting from metal-to-metal contact. Another example to mitigate ignition is to place non-rated equipment outside of classified areas.

The CSB concludes that Chesapeake's contractors neither evaluated the potential classified locations nor adequately controlled the siting of ignition sources that were in proximity to the open wellbore resulting in the ignition of the flammable gas mixture following the blowout of the well. Had Chesapeake's contractors assessed the classified areas and the associated siting of potential ignition sources, the flammable gases released during the blowout could have been prevented from igniting, and the incident could have been prevented.

## KEY LESSON

All phases of well operations, including workovers, can involve potential ignition sources, some of which cannot be eliminated. To mitigate the potential for the ignition of flammable material at well sites, companies should incorporate ignition source risk assessments into their policies and adhere to industry guidance and regulations on ignition source placement, including the use of properly rated equipment.

---

<sup>a</sup> 29 CFR 1910.307(c)

<sup>b</sup> 29 CFR 1910.307(c)(2)(i)

## 4.4 FEDERAL REGULATORY SAFETY REQUIREMENTS

In conjunction with several of its proposed and final rulemakings, OSHA has historically stated that onshore oil and gas drilling and servicing<sup>a</sup> operations should be regulated under a standard specific to that industry. On December 28, 1983, OSHA issued a proposed rulemaking under 29 CFR 1910.270 to create requirements for the oil and gas well drilling and servicing industry, entitled “Oil and Gas Well Drilling and Servicing.”<sup>b</sup> In the preamble to the proposed rule, OSHA stated that “[w]orkers in the oil and gas well drilling and servicing industry are exposed to a number of hazards associated with both the equipment and various operations performed during the course of drilling or servicing” and that this industry “has many unique hazards or special work circumstances which require special standards.” Despite the need for such a standard, OSHA never finalized the proposed regulation [32].

### 4.4.1 CONTROL OF HAZARDOUS ENERGY

In the preamble to OSHA’s final rule establishing its Control of Hazardous Energy standard in September 1989, OSHA stated that it excluded oil and gas well drilling and servicing operations from the standard<sup>c</sup> because the agency had already undertaken rulemaking with regard to these activities (48 Fed. Reg. 57202) and because OSHA believed at that time that oil and gas well drilling and servicing operations should be covered by a standard designed to address the unique nature of that industry.<sup>d</sup> The Control of Hazardous Energy standard exemption for oil and gas well drilling and servicing operations still exists today, although, as noted above, OSHA has never issued a rule specifically addressing oil and gas well drilling and servicing operations.<sup>e</sup>

The Control of Hazardous Energy standard “covers the servicing and maintenance of...equipment in which the unexpected...release of stored energy could cause injury to employees” [33]. As noted, however, the standard specifically exempts oil and gas well drilling and servicing activities [33].

Well control can be defined as preventing formation fluids from entering the wellbore or stopping the well from flowing if fluids do enter the wellbore [34]. Well control principles can also be described as preventing the release of stored energy, consistent with the scope of OSHA’s Control of Hazardous Energy standard, considering that formation fluids are under pressure.

---

<sup>a</sup> Historically, OSHA has defined “oil well drilling and servicing” as covering “activities related to the initial drilling of a well and later, maintenance work necessary to maintain or enhance production. Normally, such operations are occurring if a drilling rig or truck-mounted rig or mast is present on the well. Oil well drilling and servicing includes the following activities: 1. The actual drilling and associated activities of the well. 2. Well completion activities (i.e., activities and methods necessary to prepare a well for the production of oil and gas). 3. Well servicing (i.e., the maintenance work performed on an oil or gas well to improve or maintain the production from a formation already producing. Usually, it involves repairs to the pump, rods, gas-lift valves, tubing, packers and so forth). 4. Workover activities (i.e., the performance of one or more of a variety of remedial operations on a producing oil well to try to increase production. Examples of operations include deepening, plugging back, pulling and resetting liners, squeeze cementing, and so on.” [https://www.osha.gov/laws-regs/standardinterpretations/1999-12-20#:~:text=OSHA%20has%20stated%20in%20previous,a\)\(2\)\(ii\)](https://www.osha.gov/laws-regs/standardinterpretations/1999-12-20#:~:text=OSHA%20has%20stated%20in%20previous,a)(2)(ii)).

<sup>b</sup> Available here: <https://tile.loc.gov/storage-services/service/ll/fedreg/fr048/fr048250/fr048250.pdf>.

<sup>c</sup> 29 CFR 1910.147.

<sup>d</sup> 57 Fed. Reg 6369 (February 24, 1991). <https://www.govinfo.gov/content/pkg/FR-1992-02-24/pdf/FR-1992-02-24.pdf>.

<sup>e</sup> According to the Federal Register, OSHA withdrew its consideration of an oil and gas drilling and well servicing standard on August 31, 2001, citing “resource constraints and other priorities.” <https://www.osha.gov/sites/default/files/laws-regs/federalregister/2001-12-03.pdf>

Following the Wendland 1-H well incident, on July 28, 2020, OSHA issued citations to Chesapeake, Eagle, and Forbes for not maintaining well control. Section 5(a)(1) of the Occupational Safety and Health (OSH) Act of 1970, also known as the General Duty Clause, requires companies to provide a workplace “free from recognized hazards that are causing or are likely to cause death or serious physical harm to...employees” [35]. The General Duty Clause is not instructive regarding requirements for the control of hazardous energy for oil and gas drilling and well servicing activities, however, and therefore, lacks sufficient warning to employers to prevent incidents.

**Table 2** below outlines sections of the Control of Hazardous Energy standard and how, if applied to the Wendland 1-H well, it may have prevented the incident from occurring.

**Table 2.** Applicability of OSHA’s control of hazardous energy standard. (Credit: CSB)

| Control of Hazardous Energy standard       |   | Applicability  |
|--|---|--|
| 1910.147(c)(1)<br>Energy control program   | The employer shall establish a program consisting of energy control procedures, employee training and periodic inspections to ensure that before any employee performs any servicing or maintenance ... where the unexpected energizing, start up or release of stored energy could occur and cause injury, the machine or equipment shall be isolated from the energy source, and rendered inoperative.  | Section 4.1<br><br>Including well control procedures, supplemented by periodic inspections as part of its energy control program would have increased the likelihood of Chesapeake ensuring that effective barriers were in place for the duration of the workover.  |
| 1910.147(c)(4)<br>Energy control procedure | The procedures shall clearly and specifically outline the scope, purpose, authorization, rules, and techniques to be utilized for the control of hazardous energy, and the means to enforce compliance including, but not limited to, the following [(ii)]:<br><br>Specific procedural steps for shutting down, isolating, blocking and securing machines or equipment to control hazardous energy. [(ii)(B)]<br><br>Specific requirements for testing a machine or equipment to determine and verify the effectiveness of ... energy control measures. [(ii)(D)] | Section 4.1<br><br>This would have required Chesapeake to provide detailed well control procedures for how to isolate the well from workers on the surface. This would have required Chesapeake to detail the steps of the workover to ensure effective barriers were in place at each step. This also would have required Chesapeake to ensure that there were requirements in place to verify the effectiveness of the energy control measures in place. |
| 1910.147(d)(5)<br>Stored energy            | Following the application of ... energy isolating devices, all potentially hazardous stored or residual energy shall be relieved, disconnected, restrained, and otherwise rendered safe. [(i)]  | Section 4.2.1<br><br>While Chesapeake’s contractors did not monitor the effectiveness of the hydrostatic barrier, this would have required   |



|  |  |  |
|--|--|--|
|  | If there is a possibility of reaccumulating stored energy to a hazardous level, verification of isolation shall be continued until the servicing or maintenance is completed, or until the possibility of such accumulation no longer exists. [(ii)] | Chesapeake and its contractors to ensure the isolation was effective (through some verification or monitoring process) until the workover was completed. |
|--|--|--|

The CSB believes that well control principles (i.e., preventing the release of stored energy) are equivalent to controlling hazardous energy. Therefore, the CSB concludes that had more defined OSHA direction to oil and gas companies been in place -- such as including oil and gas drilling, well servicing, production, and workover operations in OSHA's Control of Hazardous Energy standard -- Chesapeake and its contractors may have taken greater measures to ensure positive well control was maintained throughout its operation, thereby preventing the incident from occurring.

The CSB recommends that OSHA remove the exemption for oil and gas drilling and well servicing from the Control of Hazardous Energy standard (29 CFR 1910.147) and expand its application to cover oil and gas production and workover operations.

## 4.4.2 PROCESS SAFETY MANAGEMENT

OSHA also has exempted oil and gas drilling and servicing from the Process Safety Management of highly hazardous chemicals (PSM) standard.

In OSHA's preamble to its final rule for the PSM standard, which was adopted in 1992, OSHA stated that it excluded oil and gas well drilling and servicing operations because the agency had already undertaken a rulemaking regarding these activities (48 Fed. Reg. 57202). The PSM standard exemption for oil and gas well drilling and servicing operations still exists today, although, as noted, OSHA has never finalized a rule specifically addressing these operations.

OSHA addressed the issue of regulating oil and gas drilling and servicing once again in 2013, following President Obama's Executive Order (EO) 13650, *Improving Chemical Facility Safety and Security*. Section 6(e)(ii) of EO 13650 required OSHA to publish, within 90 days, a Request for Information (RFI) designed to identify issues related to modernization of its PSM standard and other related standards needed to meet the stated goal of preventing major chemical accidents.

OSHA published a RFI on December 9, 2013, on potential revisions to several agency standards, including the PSM standard. With regard to oil and gas well drilling and servicing, the agency stated:

Paragraph (a)(2)(ii) of § 1910.119 exempts oil- and gas-well drilling and servicing operations from PSM coverage. The preamble to the PSM final rule explained that OSHA excluded these operations because it had begun a separate rulemaking for oil and gas well drilling and servicing operations (48 FR 57202). However, the Agency subsequently removed the oil and gas well drilling and servicing operations rulemaking from its regulatory agenda and never promulgated a final rule for these operations. In light of this history,

OSHA requests public comment on whether to retain or remove the § 1910.119(a)(2)(ii) exemption.<sup>a</sup>

The CSB submitted a response to the RFI on March 31, 2014. In its comments, the CSB specifically provided input on changes needed for the regulation of oil and gas well drilling and servicing operations. The CSB stated that it had identified 1,285 incidents between 2009 and February 2014, resulting in a serious injury, a fatality to a worker, an evacuation or a shelter in place of more than 500 residents; a facility impact of more than \$500,000; and/or significant environmental damage. One-hundred-three (103) – or eight percent -- of these incidents occurred in the oil and gas sector. The CSB also stated that it had encountered numerous hot work activities where explosions and fires occurred from the ignition of flammable vapors in a confined area, such as a tank, typically during maintenance. As renowned process safety expert Dr. Trever Kletz noted: “Errors in the preparation of equipment for maintenance are one of the commonest causes of serious accidents in the chemical and allied industries” [36, p. 807]. Based on the high rate of worker injuries and fatalities within these sectors, the CSB urged OSHA to eliminate the PSM exemption for oil and gas well drilling and servicing. The CSB believed then, and still believes, that making all of -- or at least the most pertinent parts of -- the PSM standard applicable to these industries would significantly improve safety and better protect workers far more than citations for General Duty Clause violations.

The activities at the Wendland 1-H well at the time of the incident were not regulated by OSHA’s PSM standard. However, had Chesapeake developed and implemented a safety management system, such as that required under OSHA’s PSM standard, specifically for workovers, the incident might not have occurred. **Table 3** outlines requirements from OSHA’s PSM standard that, if applied to the Wendland 1-H well at the time of the incident, might have prevented the incident from occurring.

**Table 3.** Applicability of OSHA’s PSM standard. (Credit: CSB)

| OSHA PSM language   | Applicability  |
|---|--|
| <u>1910.119 (d) Process Safety Information</u>  |  |
| Safe upper and lower limits for such items as ... pressures, ...or compositions; and [(2)(i)(D)]                          | This could have required Chesapeake to evaluate the consequence of deviations in, at least, pressure at the surface and/or the composition/concentration of flammable material exiting the well during workovers (i.e., %LEL <sup>b</sup> ). Chesapeake then could have defined for workers and contractors the steps to follow if a deviation toward an unsafe condition is detected to ensure the safety of workers in the area. |
| An evaluation of the consequences of deviations, including those affecting the safety and health of employees [(2)(i)(E)] |  |

<sup>a</sup> Available: <https://www.regulations.gov/document?D=OSHA-2013-0020-0001>

<sup>b</sup> OSHA defines LEL as the minimum concentration of vapor in air below which propagation of a flame does not occur in the presence of an ignition source.

|  |   |
|--|---|
| Information pertaining to the equipment in the process – Electrical classification [(3)(i)(C)]   | This could have required Chesapeake to identify the electrical classification for the area around the well and identify the equipment ratings allowed in those areas.   |
| Design codes and standards employed [(3)(i)(F)]  | This could have required Chesapeake to document the standards employed, specifically API RP 59 that states the need for documenting well history to develop well control methods.   |
| <u>1910.119 (e) Process Hazard Analysis</u>  |   |
| The process hazard analysis ... shall identify, evaluate, and control the hazards involved in the process... includes such considerations as the ... operating history of the process [(1)]  | This could have required Chesapeake to conduct a hazard analysis on each step of the workover, taking into consideration the well history. This also would have allowed Chesapeake and its contractors to ensure that more effective well control barriers were in place.   |
| The process hazard analysis shall address: the hazards of the process; the identification of any previous incident which had a likely potential for catastrophic consequences in the workplace; engineering and administrative controls applicable to the hazards and their interrelationships such as appropriate application of detection methodologies to provide early warning of releases (acceptable detection methods might include process monitoring and control instrumentation with alarms, and detection hardware such as hydrocarbon sensors); consequences of failure of engineering and administrative controls [(3)] | This could have required Chesapeake to conduct a review of the well history, engineering, and administrative controls for well control, determine potential methods for monitoring well conditions that may provide detection of possible well blowouts, and the consequences associated with the failure of engineering and administrative controls. |
| <u>1910.119(f) Operating Procedures</u>  |   |
| The employer shall develop and implement operating procedures that provide clear instructions for safely conducting activities involved in each covered process consistent with the  | This could have required Chesapeake to develop and ensure compliance (by its contractors) with procedures for well workovers. These procedures would have included steps for each phase of the workover   |

|  |  |
|--|--|
| <p>process safety information and shall address at least the following elements.</p> <ul style="list-style-type: none"> <li>- Steps for each operating phase</li> <li>- Operating limits: Consequences of deviation; and steps required to correct or avoid deviation</li> </ul> <p>[(1)]</p> <p>Precautions necessary to prevent exposure, including engineering controls, administrative controls, and personal protective equipment. [(1)(iii)(B)]</p> <p>The employer shall develop and implement safe work practices to provide for the control of hazards ... These safe work practices shall apply to employees and contractor employees. [(4)]</p> | <p>and steps that workers should take to prevent exposure to hazards, such as flammable gas.</p> |
|--|--|

The CSB concludes that had Chesapeake been required to maintain Process Safety Information (PSI), as defined in **Table 3**, utilized that PSI to evaluate the hazards (working over an open well that is venting flammable gas to atmosphere in the presence of multiple ignition sources) of the workover, and utilized that hazard evaluation to write detailed specific procedures to conduct all workover and servicing operations, the incident may not have occurred. Furthermore, a performance standard, similar to the OSHA PSM standard, would have required Chesapeake and its contractors to develop policies and procedures that could have prevented the incident.

#### 4.4.3 JUSTIFICATION FOR FEDERAL REGULATION

A federal standard tailored to the unique hazards of the oil and gas drilling and servicing, production and workover industries could drive positive safety change. In the years since OSHA's initial proposal and subsequent removal of the oil and gas drilling and serving rulemaking, there have been lessons learned from more recent incidents and continued development of good industry practice guidelines.

##### OSHA's Onshore Oil and Gas SEPs

OSHA's special emphasis programs (SEPs) provide a framework for the agency to do outreach and conduct programmed inspections in industries with potentially high injury or illness rates. The oil and gas industry involves many hazards, including working with high pressure oil and gas systems, working in hazardous

locations with explosive concentrations of hydrocarbons, and the potential for high exposures to hydrogen sulfide, and/or other health hazards.<sup>a</sup>

OSHA's regional offices in Regions III, VI, and VIII have been conducting targeted inspections of oil and gas worksites since at least 2010, under SEPs (referred to as Regional Emphasis Programs – REPs) (see **Table 4**)<sup>b</sup>

**Table 4.** OSHA regions conducting targeted inspections. (Credit: CSB)

| Region | Affected Areas  |
|--------|---|
| III    | District of Columbia, Delaware, Maryland, Pennsylvania, Virginia, and West Virginia |
| VI     | Arkansas, Louisiana, Oklahoma, and Texas  |
| VIII   | Colorado, North Dakota, South Dakota, Montana, Wyoming, and Utah                    |

The Wendland 1-H Well is located in Texas, which is in OSHA Region VI. During FY 2019, Region VI conducted 2,017 inspections for activities<sup>c</sup> such as, but not limited to, drilling, exploration, workover, and servicing. Region VI also investigated 19 fatal injuries and 35 employer-reported referrals during FY 2019 alone, under its REP. Region VI noted that explosion and fire hazards are among the leading causes of death within the oil and gas industry. Region VI also has stated:<sup>d</sup>

Since OSHA has no national program dealing with this industry, a regional emphasis program is necessary to address the fatalities/catastrophes and severe injuries and illness occurring within this jurisdiction.

#### Pryor Trust incident

The CSB investigated the gas well blowout and fire at the Pryor Trust well in Pittsburg County, Oklahoma in January 2018. This incident occurred during drilling operations, which are exempt from OSHA regulations.

The Pryor Trust incident involved multiple safety issues similar to the safety issues discussed in this report for the Wendland 1-H well blowout, such as: poor barrier management, lack of adequate procedures, and lack of safety regulation requirements. From the Pryor Trust investigation, the CSB issued the following recommendation to OSHA:

Implement one of the three following options regarding regulatory changes:

<sup>a</sup> [https://www.osha.gov/sites/default/files/enforcement/directives/reg3\\_fy2018\\_2018-01\\_0.pdf](https://www.osha.gov/sites/default/files/enforcement/directives/reg3_fy2018_2018-01_0.pdf).

<sup>b</sup> <https://www.ncbi.nlm.nih.gov/pmc/articles/PMC4469339/>

<sup>c</sup> [Regional Emphasis Program for the Upstream Oil and Gas Industry \(osha.gov\)](https://www.osha.gov)

<sup>d</sup> [Regional Emphasis Program for the Upstream Oil and Gas Industry \(osha.gov\)](https://www.osha.gov)

- (a) OPTION 1: Apply the Process Safety Management (PSM) standard (29 CFR 1910.119) to the drilling of oil and gas wells; or
- (b) OPTION 2: Apply the Process Safety Management (PSM) standard (29 CFR 1910.119) to the drilling of oil and gas wells as in OPTION 1, and make the necessary modifications to customize it to oil and gas drilling operations; or
- (c) OPTION 3: Develop a new standard with a safety management system framework similar to PSM that applies only to the drilling of onshore oil and gas wells that includes but is not limited to the following:
  - 1) Detailed written operating procedures with specified steps and equipment alignment for all operations;
  - 2) Written procedures for the management of changes (except replacements in kind) in procedures, the well plan, and equipment;
  - 3) A risk assessment of hazards associated with the drilling plan;
  - 4) A requirement to follow Recognized and Generally Accepted Good Engineering Practices (RAGAGEP);
  - 5) Development of a Well Construction Interface Document between the operator and the drilling contractor prior to the commencement of drilling activities which at a minimum includes a bridging document and well plan specifying barriers and how to manage them;
  - 6) The performance and documentation of flow checks using acceptable methods at defined points during the operation for a specified duration; and
  - 7) A requirement for employee participation, similar to the Employee Participation requirement in the OSHA PSM standard.

This recommendation to OSHA remains open.

The CSB concludes that while the Pryor Trust incident was a result of drilling operations, which is not the same as the workover operations that were ongoing during the Wendland incident, it underscores the need for federal regulations for the onshore oil and gas industry.

#### Federal Onshore Oil and Gas Regulation

OSHA can begin rulemaking for several reasons, including injuries and illnesses affecting workers<sup>a</sup>. The first step of the OSHA rulemaking process involves the identification of serious safety or health hazards. After these hazards are identified, data are gathered to determine the scope of the problem and determine the information

---

<sup>a</sup> <https://www.osha.gov/laws-regs/rulemakingprocess#v-nav-tab0>

needed for further analyses including health effects assessment, risk assessment, technological feasibility analysis, and economic analysis.<sup>a</sup> The information previously gathered by OSHA in the agency's original rulemaking proposal, combined with the information gathered through SEPs, can be used to support a rulemaking effort now.

The CSB concludes that an industry-specific federal standard for the oil and gas industry, incorporating the lessons learned and information gathered from SEPs and the CSB's investigation reports on the Pryor Trust Fatal Gas Well Blowout and Fire and this investigation report, is necessary.

Therefore, the CSB supersedes CSB Recommendation No. 2018-01-I-OK-R1 from the Pryor Trust Fatal Gas Well Blowout and Fire report and recommends that OSHA promulgate a new standard with prescriptive requirements, similar to the Control of Hazardous Energy standard, as well as a performance-based safety management system framework, similar to the OSHA Process Safety Management (PSM), that applies to the drilling, production, and servicing/workover activities surrounding onshore oil and gas wells. At a minimum, this standard should include the following:

1. Prescriptively address requirements for primary and secondary barriers for well control;
2. Detailed written drilling, production, and servicing procedures with specified steps and equipment alignment for all operations;
3. Management of change requirements (except replacements in kind) that, at a minimum, address procedures, the well plan, and equipment;
4. A risk assessment of hazards associated with the drilling, production, and servicing/workover plans;
5. A requirement to follow Recognized and Generally Accepted Good Engineering Practices (RAGAGEP);
6. Development of a Well Construction Interface Document between the operator and the drilling contractor prior to the commencement of drilling and servicing activities and an equivalent document for production and workover contractors which, at a minimum, includes a bridging document and well plans specifying barriers and how to manage them;
7. The performance and documentation of flow checks using acceptable methods at defined points during the operation for a specified duration;
8. A requirement for employee participation, similar to the Employee Participation requirement in the OSHA PSM standard;
9. A requirement for maintaining critical well information, similar to the Process Safety Information requirement in the OSHA PSM standard, which at a minimum includes well history and documented well control methods during workovers;

---

<sup>a</sup> [https://www.osha.gov/sites/default/files/OSHA\\_FlowChart.pdf](https://www.osha.gov/sites/default/files/OSHA_FlowChart.pdf)

10. A requirement for analyzing and assessing the hazards during all phases and steps for well servicing, similar to the Process Hazard Analysis requirement in the OSHA PSM standard;
11. A requirement for developing, executing, communicating, and maintaining procedures for drilling, production, and servicing operations on a well, similar to the Operating Procedures requirement in the OSHA PSM standard; and
12. The documentation of well control plans for drilling, production, and servicing/workover operations for a well utilizing acceptable methods for monitoring the effectiveness of well control methods.



## 5 CONCLUSIONS

### 5.1 FINDINGS

1. Based on shut-in pressures observed before and after the incident, the well blowout occurred as a result of both a loss of fluid overbalance and a change in the reservoir conditions, allowing oil and gas to flow to the surface.
2. A review of the well history, as recommended by API RP 59, would have revealed past instances where the Wendland 1-H well could flow oil during a workover. Such recognition may have led to heightened awareness of the potential for well control problems and earlier action taken to maintain well control.
3. Chesapeake did not provide written operating or contingency procedures for establishing and maintaining well control. Had Chesapeake and its contractors performed well planning in accordance with API RP 59, an operating procedure describing the instructions for establishing and maintaining well control would have been prepared and posted for use by contractors performing the workover operations.
4. Chesapeake failed to provide effective well control guidance, and Chesapeake's contractors failed to maintain an effective hydrostatic barrier because Chesapeake's Barrier Policy did not incorporate appropriate methods for maintaining a hydrostatic barrier for a completed well in an underpressured reservoir.
5. The use of open surface valves and stabbing valves as a well control barrier is not effective since it (1) is a mitigative control actuated after the release begins and (2) increases the risks to workers in the event of a release by creating a flammable vapor cloud around them with potential ignition sources nearby.
6. Present API guidance for well control involving completed wells in underpressured reservoirs is not adequate for the implementation of an effective hydrostatic barrier. Had more robust guidance been presented in API RP 59, Chesapeake may have instituted more effective well control practices, potentially preventing the incident from occurring.
7. Working in the presence of gas during workover operations was a common practice. This practice may have been normalized as a result of API RP 59 language that allows operators to consider flow potential rather than stipulate the recommendation for a two-barrier-to-flow system, and that API RP 59 language regarding the consideration of a two-barriers-to-flow system does not provide adequate guidance to companies operating underpressured wells.
8. Chesapeake's contractors neither evaluated the potential classified locations nor adequately controlled the siting of ignition sources that were in proximity to the open wellbore resulting in the ignition of the flammable gas mixture following the blowout of the well. Had Chesapeake's contractors assessed the classified areas and the associated siting of potential ignition sources, the flammable gases released during the blowout could have been prevented from igniting, and the incident could have been prevented.
9. OSHA currently exempts oil and gas well servicing activities from its Control of Hazardous Energy standard. Had more defined OSHA direction to oil and gas companies been in place -- such as including oil and gas drilling, well servicing, production, and workover operations in OSHA's Control of Hazardous

Energy standard -- Chesapeake and its contractors may have taken greater measures to ensure positive well control was maintained throughout its operation, thereby preventing the incident from occurring.

10. Had Chesapeake been required to maintain Process Safety Information (PSI), utilized that PSI to evaluate the hazards (working over an open well venting flammable gas to atmosphere in the presence of multiple ignition sources) of the workover, and utilized that hazard evaluation to write detailed specific procedures to conduct all workover and servicing operations, the incident may not have occurred.
11. While the Pryor Trust incident was a result of drilling operations, which is not the same as the workover operations that were ongoing during the Wendland incident, it underscores the need for federal regulations for the onshore oil and gas industry. A performance standard, similar to the OSHA PSM standard, would have required Chesapeake and its contractors to develop policies and procedures that could have prevented the incident.
12. An industry-specific federal standard for the oil and gas industry, incorporating the lessons learned and information gathered from SEPs and the CSB's investigation report on the Pryor Trust Fatal Gas Well Blowout and Fire and this investigation report, is necessary.

## 5.2 CAUSE

The CSB determined that the cause of the Wendland 1-H well blowout was the lack of well planning regarding the implementation of well control. Insufficient industry guidance regarding well control for completed wells in underpressured reservoirs contributed to the blowout, resulting in ineffective well control practices for these types of wells. The attempted well control barriers were ineffective, resulting in the release of hydrocarbons that ignited upon finding an ignition source.

The CSB also determined that ineffective ignition source management contributed to the fire, resulting in three fatal injuries and one serious injury. The absence of regulations governing onshore oil and gas operations contributed to the incident, resulting in the failure to both effectively control hazardous energy and implement essential risk assessments that could have prevented this incident.

## 6 RECOMMENDATIONS

### 6.1 PREVIOUSLY ISSUED RECOMMENDATIONS SUPERSEDED IN THIS REPORT

#### 2018-01-I-OK-R1 (from the Pryor Trust Fatal Gas Well Blowout and Fire report)

##### To the Occupational Safety and Health Administration

Implement one of the three following options regarding regulatory changes:

- a. OPTION 1: Apply the Process Safety Management (PSM) standard (29 CFR 1910.119) to the drilling of oil and gas wells; or
- b. OPTION 2: Apply the Process Safety Management (PSM) standard (29 CFR 1910.119) to the drilling of oil and gas wells as in OPTION 1, and make the necessary modifications to customize it to oil and gas drilling operations; or
- c. OPTION 3: Develop a new standard with a safety management system framework similar to PSM that applies only to the drilling of onshore oil and gas wells that includes but is not limited to the following:
  1. Detailed written operating procedures with specified steps and equipment alignment for all operations;
  2. Written procedures for the management of changes (except replacements in kind) in procedures, the well plan, and equipment;
  3. A risk assessment of hazards associated with the drilling plan;
  4. A requirement to follow Recognized and Generally Accepted Good Engineering Practices (RAGAGEP);
  5. Development of a Well Construction Interface Document between the operator and the drilling contractor prior to the commencement of drilling activities which at a minimum includes a bridging document and well plan specifying barriers and how to manage them;
  6. The performance and documentation of flow checks using acceptable methods at defined points during the operation for a specified duration; and
  7. A requirement for employee participation, similar to the Employee Participation requirement in the OSHA PSM standard.

*Superseded by 2020-04-I-TX-R4 to OSHA below.*

## 6.2 RECOMMENDATIONS ISSUED IN THIS REPORT

To prevent future chemical incidents, and in the interest of driving chemical safety excellence to protect communities, workers, and the environment, the CSB makes the following safety recommendations:

### 6.2.1 CHESAPEAKE OPERATING, L.L.C.

#### 2020-04-I-TX-R1

Develop or revise policies incorporating the recommendations of API RP 59 regarding well planning, specifically the inclusion of well history review in conjunction with workover well control planning.

### 6.2.2 AMERICAN PETROLEUM INSTITUTE

#### 2020-04-I-TX-R2

Publish the following information in an appropriate document such as API RP 59 *Recommended Practice for Well Control Operations*:

1. A focused discussion on practices applicable to workover operations, including completed wells in underpressured reservoirs. Include well control methods applicable to workover operations, such as using continuous fluid addition, viscous fluids, bridging solids, and mechanical plugs. Also include a discussion on the well control challenges and hazards specific to workover operations;
2. Stabbing valves should not be considered as well control barriers for workover operations; and
3. Every well should be considered to have potential to flow, and therefore, should have two well control barriers, one of which should be a preventative barrier.

### 6.2.3 OCCUPATIONAL SAFETY AND HEALTH ADMINISTRATION

#### 2020-04-I-TX-R3

Remove the exemption for oil and gas drilling and well servicing from the Control of Hazardous Energy standard (29 CFR 1910.147) and expand its applicability to cover oil and gas production and workover operations.

#### 2020-04-I-TX-R4

Promulgate a new standard with prescriptive requirements, similar to the Control of Hazardous Energy Standard, as well as a performance-based safety management system framework, similar to the OSHA Process Safety Management (PSM) Standard, that applies to the drilling, production, and servicing/workover activities surrounding onshore oil and gas wells. At a minimum, this standard should include the following:

1. Prescriptively address requirements for primary and secondary barriers for well control;

2. Detailed written drilling, production, and servicing procedures with specified steps and equipment alignment for all operations;
3. Management of change requirements (except replacements in kind) that, at a minimum, address procedures, the well plan, and equipment;
4. A risk assessment of hazards associated with the drilling, production, and servicing/workover plans;
5. A requirement to follow Recognized and Generally Accepted Good Engineering Practices (RAGAGEP);
6. Development of a Well Construction Interface Document between the operator and the drilling contractor prior to the commencement of drilling and servicing activities and an equivalent document for production and workover contractors which, at a minimum, includes a bridging document and well plans specifying barriers and how to manage them;
7. The performance and documentation of flow checks using acceptable methods at defined points during the operation for a specified duration;
8. A requirement for employee participation, similar to the Employee Participation requirement in the OSHA PSM standard;
9. A requirement for maintaining critical well information, similar to the Process Safety Information requirement in the OSHA PSM standard, which at a minimum includes well history and documented well control methods during workovers;
10. A requirement for analyzing and assessing the hazards during all phases and steps for well servicing, similar to the Process Hazard Analysis requirement in the OSHA PSM standard;
11. A requirement for developing, executing, communicating, and maintaining procedures for drilling, production, and servicing operations on a well, similar to the Operating Procedures requirement in the OSHA PSM standard; and
12. The documentation of well control plans for drilling, production, and servicing/workover operations for a well utilizing acceptable methods for monitoring the effectiveness of well control methods.

## 7 KEY LESSONS FOR THE INDUSTRY

To prevent future chemical incidents, and in the interest of driving chemical safety excellence to protect communities, workers, and the environment, the CSB urges companies to review these key lessons:

1. To successfully execute well control, proper well planning is required. Industry guidance recommends gathering well information, evaluating potential hazards based on that information, and creating operating procedures and contingency plans to address those hazards. Companies should incorporate well planning, based on industry guidance, into their well control policies and procedures.
2. Despite having substantial industry guidance regarding how companies should conduct well control, industry guidance is lacking regarding specific well control methods for completed wells in underpressured reservoirs. Companies that operate these types of wells need to be aware of this gap and use necessary resources, such as other recognized technical literature, such as *Well Control for Completions and Interventions* by H. Crumpton, when creating well control policies and procedures for workovers.
3. All phases of well operations, including workovers, can involve potential ignition sources, some of which cannot be eliminated. To mitigate the potential for the ignition of flammable material at well sites, companies should incorporate ignition source risk assessments into their policies and adhere to industry guidance and regulations on ignition source placement, including the use of properly rated equipment.

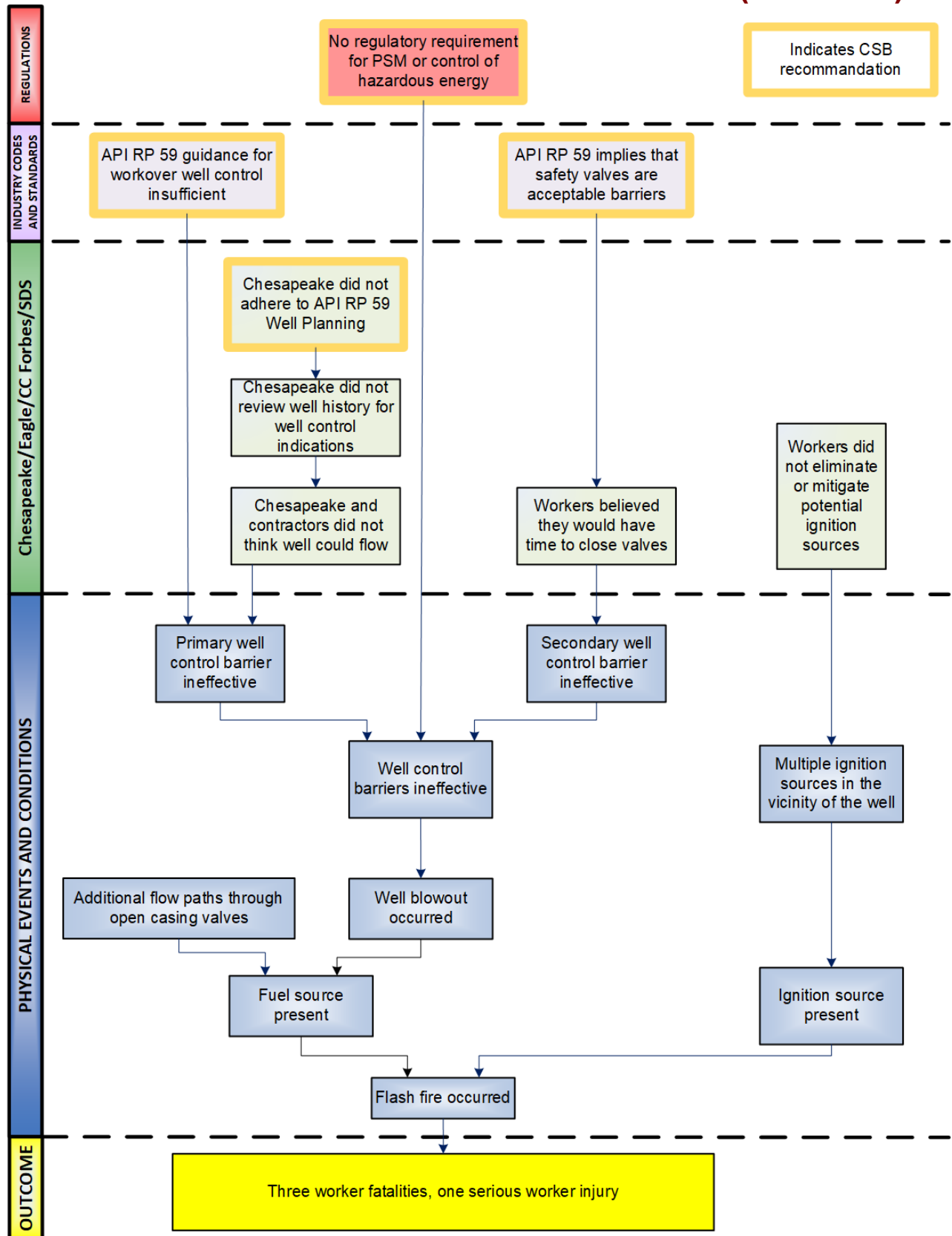
## 8 REFERENCES

- [1] International Association of Drilling Contractors, "IADC\Drilling Lexicon, Oil and Gas Drilling Glossary," [Online]. Available: <https://iadclexicon.org/>. [Accessed 02 October 2023].
- [2] OilGasGlossary.com, "Oil and Gas Field Technical Terms Glossary," OilGasGlossary.com, [Online]. Available: [http://oilgassglossary.com/rod\\_string.html](http://oilgassglossary.com/rod_string.html). [Accessed 02 October 2023].
- [3] GoHaynesvilleShale.com, "Shale Plays," GoHaynesvilleShale.com, 2017. [Online]. Available: <https://gohaynesvilleshale.com/shale-plays>. [Accessed 4 April 2023].
- [4] U.S. Energy Information Administration, "About EIA," U.S. Energy Information Administration, 2023. [Online]. Available: <https://www.eia.gov/about/>. [Accessed 25 August 2023].
- [5] U.S. Energy Information Administration, "U.S. Oil and Natural Gas Wells by Production Rate," U.S. Energy Information Administration, 2023. [Online]. Available: <https://www.eia.gov/petroleum/wells/>. [Accessed 25 August 2023].
- [6] University of Calgary, "Energy Education\Oil and gas reservoir," [Online]. Available: [https://energyeducation.ca/encyclopedia/Oil\\_and\\_gas\\_reservoir](https://energyeducation.ca/encyclopedia/Oil_and_gas_reservoir). [Accessed 02 October 2023].
- [7] University of Calgary, "Oil Well," University of Calgary, [Online]. Available: [https://energyeducation.ca/encyclopedia/Oil\\_well](https://energyeducation.ca/encyclopedia/Oil_well). [Accessed 27 October 2023].
- [8] University of Calgary, "Energy Education\Well casing," [Online]. Available: [https://energyeducation.ca/encyclopedia/Well\\_casing#:~:text=A%20well%20casing%20is%20a,would%20collapse%20in%20witho,ut%20support](https://energyeducation.ca/encyclopedia/Well_casing#:~:text=A%20well%20casing%20is%20a,would%20collapse%20in%20witho,ut%20support). [Accessed 02 October 2023].
- [9] BMT, "CargoHandbook.com\Oil Well Casing," [Online]. Available: [https://cargohandbook.com/Oil\\_Well\\_Casing](https://cargohandbook.com/Oil_Well_Casing). [Accessed 02 October 2023].
- [10] AAPG Wiki, "Fluid flow fundamentals," MediaWiki, 19 January 2022. [Online]. Available: [https://wiki.aapg.org/Fluid\\_flow\\_fundamentals](https://wiki.aapg.org/Fluid_flow_fundamentals). [Accessed 02 October 2023].
- [11] Elsevier, Science Direct, "Science Direct\Reservoir Pressure," [Online]. Available: <https://www.sciencedirect.com/topics/engineering/reservoir-pressure#:~:text=Reservoir%20pressure%20means%20the%20pressure,to%20move%20in%20the%20reservoir>. [Accessed 17 September 2023].
- [12] R. von Flatern, "The Defining Series: Artificial Lift," Schlumberger Oilfield Review, September 2015. [Online]. Available: <https://www.slb.com/resource-library/oilfield-review/defining-series/defining-artificial-lift>. [Accessed 22 September 2023].
- [13] Schlumberger, "SLB\Energy Glossary," [Online]. Available: <https://glossary.slb.com/>. [Accessed 02 October 2023].
- [14] H. Crumpton, Well Control for Completions and Interventions, Cambridge, MA: Elsevier, 2018.
- [15] B. a. M. C. Panamarathupalayam, "Chapter 6 - Completion and workover fluids," ScienceDirect, Elsevier, Gulf Professional Publishing, 2022. [Online]. Available: <https://www.sciencedirect.com/science/article/abs/pii/B9780128227213000071#:~:text=Most%20completion%20and%20workover%20fluids,between%20the%20completion%20fluid%20and>. [Accessed 02 October 2023].
- [16] American Petroleum Institute (API), API Recommended Practice 59 (2nd Edition) - Recommended Practice for Well Control Operations, Washington: API Publishing Services, 2018.
- [17] Center for Chemical Process Safety/Society of Petroleum Engineers, Process Safety in Upstream Oil and Gas, New York: American Institute of Chemical Engineers/John Wiley & Sons, Inc., 2021.
- [18] D. Watson, T. Brittenham and P. L. Moore, Advanced Well Control, Richardson: Society of Petroleum Engineers, 2003.
- [19] C. F. Conaway, "Reservoir Heterogeneity," in *Petroleum Industry - A Nontechnical Guide*, Tulsa, PennWell Corporation, 1999, pp. 83-85.
- [20] D. Leonard, Composer, *Artificial lift oil and gas: Gas Lift Artificial Lift principle*. [Sound Recording]. YouTube, Petrolessons. 2019.
- [21] Schlumberger Limited, "Energy Glossary - complete a well," Schlumberger Limited, 2023. [Online]. Available: [https://glossary.slb.com/en/terms/c/complete\\_a\\_well](https://glossary.slb.com/en/terms/c/complete_a_well). [Accessed 8 September 2023].
- [22] presentationgo.com, "PresentationGo," [Online]. Available: <https://www.presentationgo.com/>. [Accessed 02 October 2023].
- [23] J. L. Rike, D. L. Whitman, E. R. Rike and L. R. Hardin, "Completion and Workover Needs are Different!," in *Petroleum Society of CIM/Society of Petroleum Engineers*, Calgary, 1990.
- [24] International Association of Drilling Contractors, "Oil & Gas Drilling Glossary - Secondary Well Barrier," IADC, 2023. [Online]. Available: <https://iadclexicon.org/secondary-well-barrier/>. [Accessed 11 September 2023].
- [25] M&M International, "Products," BREW, [Online]. Available: <https://www.mmvalve.com/products/>. [Accessed 24 August 2023].

- [26] B. Builder, "Weatherford, danger, casing, oilfield fail, Workover rig blowout, well c," 10 July 2015. [Online]. Available: <https://www.youtube.com/watch?v=UCcUGksr5EU>. [Accessed 8 November 2023].
- [27] AlphaZERO, "TIW valve? anyone?," 3 February 2021. [Online]. Available: <https://www.youtube.com/watch?v=8UFZEcN2uFQ>. [Accessed 8 November 2023].
- [28] American Petroleum Institute, Recommended Practice for Classification of Locations for Electrical Installations at Petroleum Facilities Classified as Class I, Division 1 and Division 2 (2nd Edition), Washington: API, 1997.
- [29] American Petroleum Institute, Occupational Safety and Health for Oil and Gas Well Drilling and Servicing Operations (4th Edition), Washington: API Publishing Services, 2019.
- [30] American Petroleum Institute, Flash Fire Risk Assessment for the Upstream Oil and Gas Industry, Washington: API Publishing Service, 2014.
- [31] T. Kletz and P. Amyotte, What Went Wrong? - Case Histories of Process Plant Disasters and How They Could Have Been Avoided, Cambridge: Elsevier, 2019.
- [32] M. Soraghan, "Drilling's safety exemptions and how they got there," *E&E News*. <https://subscriber.politicopro.com/article/eenews/2014/11/04/drillings-safety-exemptions-and-how-they-got-there-104181>, 4 November 2014.
- [33] U.S. Occupational Safety and Health Administration, "The control of hazardous energy (lockout/tagout)," National Archives, 25 August 2023. [Online]. Available: <https://www.ecfr.gov/current/title-29/subtitle-B/chapter-XVII/part-1910/subpart-J/section-1910.147>. [Accessed 5 September 2023].
- [34] Schlumberger Limited, "Energy Glossary - well control," Schlumberger Limited, 2023. [Online]. Available: [https://glossary.slb.com/en/terms/w/well\\_control](https://glossary.slb.com/en/terms/w/well_control). [Accessed 5 September 2023].
- [35] Occupational Safety and Health Administration, "OSH Act of 1970 - General Duty Clause," OSHA, 2023. [Online]. Available: <https://www.osha.gov/laws-regs/oshaact/section5-duties>. [Accessed 13 September 2023].
- [36] T. Kletz, "Hazards in Chemical System Maintenance: Permits," in *Safety and Accident Prevention in Chemical Operations (2nd Edition)*, New York, John Wiley & Sons, 1982, p. 807.
- [37] Penn State College of Earth and Mineral Sciences, "PSU\Steady-State Flow of Oil," PSU.edu, [Online]. Available: <https://www.e-education.psu.edu/png301/node/851>. [Accessed 06 October 2023].
- [38] U.S. Census Bureau, "Census Reporter Profile page for Burleson County, TX," 2021. [Online]. Available: <https://censusreporter.org/profiles/05000US48051-burleson-county-tx/>. [Accessed 22 May 2023].
- [39] U.S. Census Bureau, "Quick Facts - United States," U.S. Census Bureau, 2023. [Online]. Available: <https://www.census.gov/quickfacts/fact/table/US/INC910221>. [Accessed 22 May 2023].
- [40] American Association of Petroleum Geologists (AAPG), "AAPG Wiki\Fluid flow fundamentals," AAPG Wiki, [Online]. Available: [https://wiki.aapg.org/Fluid\\_flow\\_fundamentals#:~:text=Darcy's%20law%2C%20which%20was%20originally,\(compressible%20and%20multiple%20phases\).&text=The%20permeability%20is%20a%20property,the%20fluid%20flows%20through%20it..](https://wiki.aapg.org/Fluid_flow_fundamentals#:~:text=Darcy's%20law%2C%20which%20was%20originally,(compressible%20and%20multiple%20phases).&text=The%20permeability%20is%20a%20property,the%20fluid%20flows%20through%20it..) [Accessed 06 October 2023].
- [41] Sinomine Speciality Fluids, "Formate Technical Manual\SectionA4\_Viscosity of Formate Brines," Sinomine Speciality Fluids, 2019. [Online]. Available: <https://formatebrines.com/wp-content/uploads/2019/10/FORMATEMANUAL-A4-Viscosity-of-Formate-Brines.pdf>. [Accessed 08 October 2023].
- [42] K. Pearson, "Geologic Models and Evaluation of Undiscovered Conventional and Continuous Oil and Gas Resources - Upper Cretaceous Austin Chalk, U.S. Gulf Coast," U.S. Department of the Interior/U.S. Geological Survey, Reston, 2012.
- [43] J. P. Brill and H. Mukherjee, Multiphase Flow in Wells, Richardson: Society of Petroleum Engineers, 1999.



## APPENDIX A—SIMPLIFIED CAUSAL ANALYSIS (ACCIMAP)



## APPENDIX B—CALCULATIONS

### Change in Wellbore Fluid Level

Upon opening the well to atmosphere on January 29, 2020, the static head pressure at the top of the wellbore went from 50 psig to zero psig (atmospheric). As a result, the liquid level in the wellbore would have risen the amount in feet equivalent to 50 psig, based on the following equation:

$$h = P/G , \quad (1)$$

where h is the amount of fluid increase in feet, P is the pressure change in psig, and G is the pressure gradient in psig per foot of the liquid column. Reducing the static head pressure at the top of the wellbore resulted in an increase in the height of the fluid column of 171 feet, bringing the estimated liquid level from 4,850 feet to 4,679 feet below the surface.

Upon pumping 50 bbls of 10-ppg brine into the well, assuming the brine addition was instantaneous, the increase in the liquid level would have been based on the capacity of the production casing. The result was calculated for a seven-inch, 23 pounds-per-foot casing using the following:

$$h = V/C , \quad (2)$$

where V represents the volume of additional fluid in barrels and C is the volumetric capacity of the casing. The addition of 50 bbls of brine, based on a given casing capacity of 0.03937 bbls per foot, added an additional 1,270 feet of fluid into the well. Based on the brine density of 10 pounds per gallon, the additional fluid resulted in a hydrostatic pressure overbalance, using Equation (1) and a brine fluid gradient of 0.52 psi per foot,<sup>a</sup> of 661 psig.

### Rate of Fluid Loss into the Reservoir

Darcy's radial inflow calculation is normally used in petroleum engineering to estimate the flow potential into a well [37]. Crumpton used the equation to estimate the rate of fluid loss into the reservoir [14, pp. 208-209]. The fluid loss rate from the wellbore can be estimated using the following equation [10]:

$$Q = \frac{7.08 \times 10^{-3} kh(P_r - P_{wf})}{\mu B [\ln(\frac{r_e}{r_w}) - 0.75 + S]} \quad (3)$$

**Table 5** explains the terms of the radial inflow equation. The value used for the fluid hydrostatic pressure was based on the initial bottom hole pressure (820 psig) plus the hydrostatic pressure of the fluid column added. The initial added fluid column was 1,270 feet which added 661 psig of fluid head pressure. Thus, the initial bottomhole pressure was 1,481 psig (661 psig plus 1,270 psig). The fluid loss rate gradually decreases as fluid is lost from the wellbore to the formation. As a simplifying assumption, the height used for the fluid loss

<sup>a</sup> Fluid gradient in psi per foot is obtained by multiplying the fluid density in ppg by 0.052.

calculation was based on the midpoint between the initial added fluid column height, 1,270 feet, or 661 psig, and the point where the added fluid is completely lost to the reservoir. The pressure associated with that midpoint is 330 psig. Therefore, the value used for the fluid hydrostatic pressure in the calculation was 1,150 psig, which is 820 psig plus 330 psig.

**Table 5.** Radial inflow equation explanation of terms.

| Term     | Explanation   | Value                  |
|----------|---|------------------------|
| $Q$      | Fluid loss rate, in bbls per hour (bbl/hour)  | 15-40                  |
| $k$      | Permeability, in millidarcy (mD)  | 0.5 <sup>1</sup>       |
| $h$      | Net height of the formation, in feet (ft.) NOTE: In this instance, since the horizontal wellbore was open to the formation, it is appropriate to use the total length of the horizontal wellbore. | 5,357                  |
| $P_r$    | Reservoir pressure, in psig   | 820                    |
| $P_{wf}$ | Fluid hydrostatic pressure, in psig   | 1,150 <sup>2</sup>     |
| $\mu$    | Fluid viscosity (brine), in centipoise (cP)   | 0.57 <sup>3</sup>      |
| $B$      | Formation volume factor (dimensionless)   | 2.17-5.77 <sup>4</sup> |
| $r_e$    | Drainage radius, in feet (ft.)  | 150 <sup>5</sup>       |
| $r_w$    | Wellbore radius, in feet (ft.)  | 0.2917                 |
| $S$      | Skin factor (dimensionless)   | 0 <sup>6</sup>         |

<sup>1</sup> Permeability was estimated based on a typical value for the Austin Chalk [38, p. 6].

<sup>2</sup> This value was obtained by adding the initial reservoir pressure to the hydrostatic pressure of the added brine calculated earlier using Eq. (2).

<sup>3</sup> Brine viscosity was obtained from published tabular data, assuming a reservoir temperature of 200°F and use of a single-salt (sodium) formate brine [37, p. 5].

<sup>4</sup> Formation volume factor was calculated using the Standing correlation, assuming a range of gas-to-oil ratios from 2100-7300, oil specific gravity of 0.80, and gas specific gravity of 0.65 [39, p. 105].

<sup>5</sup> Drainage radius was estimated to 0.65% of original reservoir oil saturation [38, pp. 12-13].

<sup>6</sup> A skin factor of zero assumes ideal pressure drop conditions across the boundary between the wellbore and the reservoir [40].

Based on the variables listed in **Table 5**, the CSB calculated an estimated fluid loss rate from the wellbore of 15 to 40 bbl/hr. Based on these results, a 50 bbl batch load of brine or fresh water would flow into the formation within 1.3 to 3.5 hours after placing the fluid in the wellbore. The reservoir temperature of 200°F is likely more reflective of conditions at the point where heavier brine fluid is lost to the formation.

To illustrate the effectiveness of a higher viscosity fluid addition, the CSB also calculated a hypothetical fluid loss rate using a polymer with a viscosity of 200 cP. Using the same variables and assumptions, the fluid loss rate using a polymer was 0.04 to 0.11 bbls/hr.

## APPENDIX C—WELL WORKOVER HISTORY

The CSB reviewed the workover history of the Wendland 1-H well. Records from 34 well workovers since 1993 were provided to the CSB. During the 34 well workovers, the well routinely relieved gas. Well control events were reported as: “well came in,” “heavy gas”, “blowing strong,” “well flowing,” “well started to flow,” etc. Most events reference relieving gas. These types of well control events were reported 22 times during the 34 workovers. Some workovers had multiple reported events.

The fluid was typically loaded into the wellbore as a single batch, averaging about 50 bbls each time. Based on review of the records, the barrier philosophy appeared to be: 1) pumping a single volume of clear fluids as a primary barrier and 2) usage of a stabbing valve as the secondary barrier.

On three 1995 workovers, the fluid was continuously added to the well. During the first two workovers, one in April and one in May, continuous fluid addition did not prevent well control events. These records also did not contain the flow rate at which fluid was added. During the June 1995 workover, fluid was added continuously at rates ranging from 0.75 to 1 bbl per minute. There were no well control events during the June 1995 workover.

In February 1996, the workover crew pumped 35 bbls of water initially. This fluid addition resulted in gas being vented at the surface. The workover crew then pumped 70 bbls of water to stop the gas from coming up, but this attempt was unsuccessful. The gas stopped only after the workover crew pumped two more batches of water at 70 bbls each, using a total of 245 bbls of water during this workover. This workover suggests that pumping water into this well may have destabilized the well, resulting in multiple well control events requiring additional volumes of fluid to be added.



## U.S. Chemical Safety and Hazard Investigation Board

### Members of the U.S. Chemical Safety and Hazard Investigation Board:

Steve Owens  
Chairperson

Sylvia Johnson, PhD  
Member

Catherine J.K. Sandoval  
Member