

SAFETY DIGEST:

PREPARING EQUIPMENT AND INSTRUMENTATION FOR COLD WEATHER OPERATIONS

20
Years of Driving Chemical Safety Change
1998
2018



U.S. Chemical Safety and
Hazard Investigation Board

U.S. Chemical Safety and Hazard Investigation Board

Preparing for Cold Weather at Chemical and Other Process Facilities

As outdoor air temperatures drop, it is important for chemical and other facilities to be prepared for the unique safety challenges posed by cold weather, such as the hazards of water freezing and expanding, which can damage equipment or cause instrumentation to fail. When the temperature drops, the freezing process begins, and materials expand. This can crack or break pipes and rupture or damage process equipment. This damaged equipment may not become evident until the temperature rises, the ice thaws, and a leak develops. More subtle hazards may also exist, such as the formation of a hydrate, where water chemically combines with a compound,

forming a solid that can also block process piping. This can happen even above freezing temperatures.

Facilities' process safety management programs, including hazard reviews, management of change (MOC) evaluations, pre-startup safety reviews, and operating procedures, should reflect a year-round focus on how low temperatures may affect piping and other equipment and instrumentation. This digest summarizes three CSB investigations where ineffective freeze protection practices and programs were found to be causal to the incident. The document also provides the key safety lessons from these incidents, as well as additional freeze protection guidance and resources.

DuPont La Porte, Texas Chemical Facility Toxic Chemical Release

- > **Incident date: November 15, 2014**
- > **Four workers killed, three workers injured**
- > [Interim Recommendations and Video Animation available on CSB website](#)

In November 2014, a release of toxic methyl mercaptan killed four workers at a pesticide manufacturing company in La Porte, Texas. Days before the incident, water mixed with liquid methyl mercaptan in piping located in an outdoor area of the plant. Due to cold weather in the Houston area, this mixture formed a solid hydrate, which blocked the piping. Although the potential for this hazard was known, the piping was not heat traced (heat applied to pipes, tanks, instruments and associated equipment) or otherwise protected to prevent a solid hydrate from blocking flow. A company team developed a plan to clear the blockage by spraying hot water onto the pipes to melt the hydrate. To prevent piping thermal expansion hazards, this plan included opening valves from the liquid piping to a vapor vent piping system.

On November 15, 2014, workers worked through the night attempting to clear the hydrate blockage. Following a failed startup, workers paused to take a break. During the break, the plant experienced a different problem — high pressure in the vent piping. The company had long-standing issues with vent piping installed in 2011. To deal with these problems, workers had daily instructions to drain liquid from the vent piping inside the manufacturing building. On the night of the incident, not realizing the original hydrate blockage had cleared, and with valve positions now open between the liquid methyl mercaptan and vapor vent piping systems, two workers were killed when liquid methyl mercaptan drained from the open valves and filled the room with toxic vapor. One of those workers made a distress call and two additional workers died responding to that call.

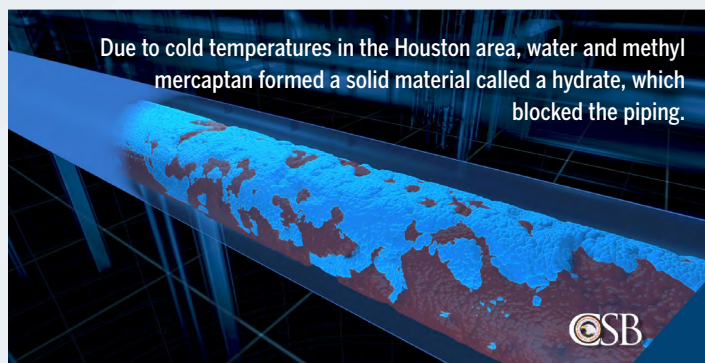

Due to cold temperatures in the Houston area, water and methyl mercaptan formed a solid material called a hydrate, which blocked the piping.

SAFETY DIGEST:

PREPARING EQUIPMENT AND INSTRUMENTATION FOR COLD WEATHER OPERATIONS

20
Years of Driving Chemical Safety Change
1998
2018



U.S. Chemical Safety and
Hazard Investigation Board

U.S. Chemical Safety and Hazard Investigation Board

Valero Refinery Propane Fire

- > **Incident Date: February 16, 2007**
- > **Four workers injured; total refinery evacuated and extended shutdown**
- > **[Full Report and Video available on CSB Website](#)**

In February 2007, a massive refinery fire occurred near the town of Dumas, Texas. The fire seriously burned three people, shut down the refinery for two months, and contributed to gasoline shortages hundreds of miles away. The fire occurred in a unit that used large amounts of high-pressure liquid propane. Years earlier, the unit had been reconfigured, creating a dead-leg, or a section of piping without any flow. Dead-legs are particularly vulnerable to the hazards of freezing. The dead-leg was blocked on one side by a valve that was later found to be leaking. Over time, small amounts of water that were contained in the liquid propane flowed past the leaking valve and accumulated in the piping below. On February 15, 2007, the outdoor air temperature fell to six degrees Fahrenheit. The water froze, expanded, and cracked the pipe. The following day, the weather warmed up, the ice melted, the propane ignited, and fire engulfed the area, injuring workers and causing more than 50 million dollars in damage.

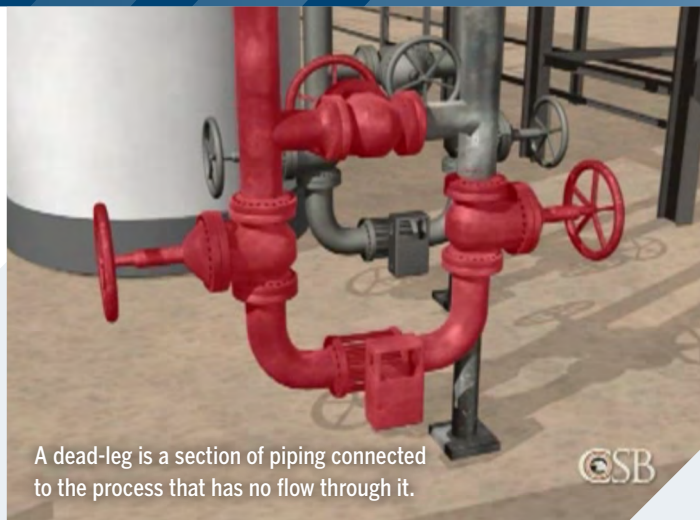

A dead-leg is a section of piping connected to the process that has no flow through it.

CSB



Crack in the 10" diameter propane mix control station inlet elbow.



A liquid propane release from the cracked control station piping resulted in a massive fire in the propane deasphalting unit, which then collapsed.

SAFETY DIGEST:

PREPARING EQUIPMENT AND INSTRUMENTATION FOR COLD WEATHER OPERATIONS

20
Years of Driving Chemical Safety Change
1998
2018



U.S. Chemical Safety and
Hazard Investigation Board

U.S. Chemical Safety and Hazard Investigation Board

Bethlehem Steel Corporation Gas Condensate Fire

- > Incident date: February 2, 2001
- > Two workers killed, four injured
- > [Full Report available on CSB Website](#)

In February 2001, an incident occurred at a steel mill in Chesterton, Indiana. This incident had its origins nine years earlier (1992), when the mill disconnected a furnace that was fueled by coke oven gas. The 25-foot pipe that once supplied gas to the furnace was left in place with a closed 10-inch valve at the bottom. It was a dead-leg. In the winter of 2001, water accumulated inside the dead-leg and froze, cracking the valve. As a crew later began work to replace the valve, they were sprayed with flammable liquid gas condensate, which ignited. The fire killed two workers and injured four others. Both the water and the flammable liquid had condensed from the coke oven gas. The accumulation of liquids accelerated because insulation was previously removed from piping and drain lines in the gas system became blocked with ice.

A crack was likely caused by the freezing and expansion of water in coke oven gas piping where condensate had accumulated above the valve.

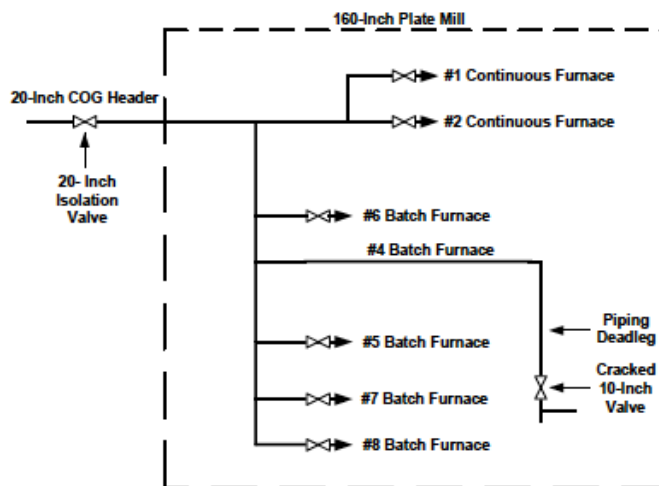

COG system in 160-inch plate mill.

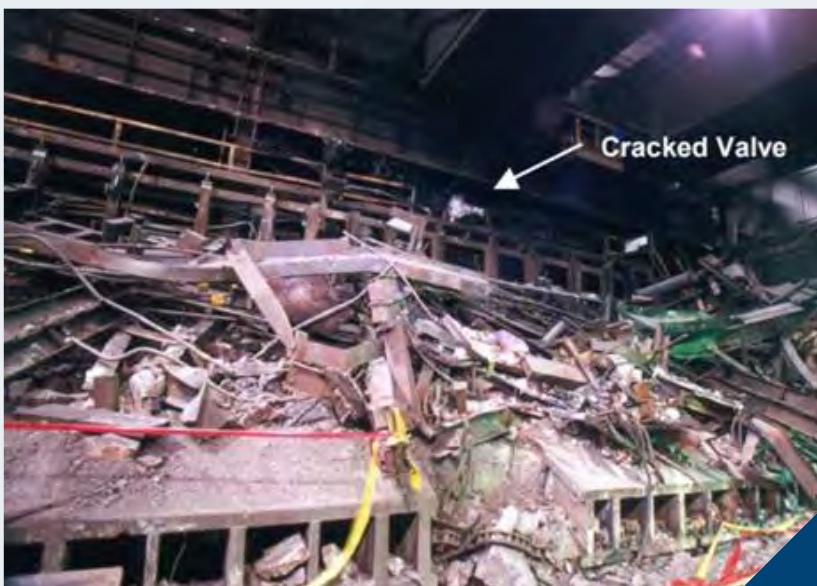

Key Winterization Safety Lessons

These three serious accidents illustrate the importance of effective winterization programs at refineries, chemical plants, and other facilities that contain hazardous materials. Dead-legs must be surveyed and, ideally, removed or permanently and effectively isolated from hazardous process streams. Equipment that is susceptible to ice or

hydrate formation in cold weather should be identified and properly winterized, such as insulating or heat tracing. Companies should establish formal, written winterization programs and identify and control winterization hazards, such as ice and hydrate formation, through process hazard analyses, MOC evaluations, pre-startup safety reviews, and operating procedures.

SAFETY DIGEST:

PREPARING EQUIPMENT AND INSTRUMENTATION FOR COLD WEATHER OPERATIONS

20
Years of Driving Chemical Safety Change
1998
2018



U.S. Chemical Safety and
Hazard Investigation Board

U.S. Chemical Safety and Hazard Investigation Board

Published guidance exists to help companies perform winterization and prepare systems for cold weather. For example, the *American Petroleum Institute (API) Recommended Practice (RP) 2001, Fire Protection in Refineries*, provides guidance for freeze protection programs at refineries. Appendix B includes a list of potential issues encountered in freezing weather and lists the suggested elements of a typical freeze protection program, including:

- Identify and document equipment vulnerable to freezing weather;
- Evaluate and select freeze protection options;
- Establish equipment-specific written plans;
- Assign a responsible party to implement plans;
- Prioritize options and, when applicable, implement them and document using MOC principles;
- Periodically audit program implementation; and
- Establish a formal, written freeze protection program.

API RP 2001 states that a freeze protection program should:

- Establish formal written programs to find cold weather vulnerabilities;
- Provide technical, operations, and maintenance personnel education and training to help them understand and recognize potential problem situations;
- Enable those people working with field equipment to recognize potential freeze hazards and identify them for remediation;
- Educate technical and maintenance personnel through training to help them avoid inadvertently creating freeze hazards as they modify equipment, revise designs, or design new equipment;
- Systematically conduct a careful review of out-of-service piping or units to identify potential problems to rectify; and
- “Design-out” dead-legs, including process bypass piping.

Facilities should also systematically review process units and survey piping systems for dead-legs and ensure they are properly isolated, removed, or winterized. Freeze failure of piping dead-legs may result in rupture, hydrocarbon release, and serious incidents.

Additional resources and industry guidance on preparing for freezing temperatures are available to include:

- [Allianz Global Corporate & Specialty Winterization Checklist.](#)
- API 2001. Fire Protection in Refineries. Ninth Edition, April 2012.
- API 661. Air-Cooled Heat Exchangers for General Refinery Service.
- [Center for Chemical Process Safety \(CCPS\) Process Safety Beacons on weather-related process safety issues.](#) “Read only” copies are available. Read the December 2001, October 2008, and October 2010 issues specifically for examples of winter weather process safety problems.
- [Chemical Processing, “Time to prepare for winter.”](#)
- [Control Engineering, “Process plant winterization strategies.”](#)
- [FM Global](#), including “Understanding the Hazard”; “Freeze-Up Checklist”; “Protecting Your Facilities from Winter Storms”; and “Protecting Your Pulp and Paper Mill from Winter Storms”.
- North American Electric Reliability Corporation, [“Reliability Guideline: Generating Unit Winter Weather Readiness – Current Industry Practices.”](#)
- Power Magazine, [“Prepare Your Gas Plant for Cold Weather Operations.”](#)